

PAGURO



The smart solution

-  Innovativo sistema di equilibratura salva spazio a lancio manuale per ruote camion ed autobus, montabile su smontagomme autocarro, particolarmente adatto anche per servizio mobile.
-  Innovative space-saver handspin balancing system for truck and bus wheels, to be mounted on truck tyre changer, particularly suitable also for mobile service.
-  Système d'équilibrage novateur économise-espace à lancement manuel pour roues de camions et autobus, montable sur un demonte-pneus de camion, particulièrement adapté pour le service mobile.
-  Innovatives platzsparendes Wuchtsystem mit Handwerfen für LKW- und Busräder, montierbar auf LKW Montiergeräte, besonders geeignet für mobilen Reifendienst.
-  Innovador sistema de equilibrado ahorra espacio a lanzamiento manual para ruedas de camiones y autobuses, que puede ser montado sobre desmontadoras de neumáticos para camiones, especialmente indicado para el servicio móvil.



PORTABLE DISPLAY

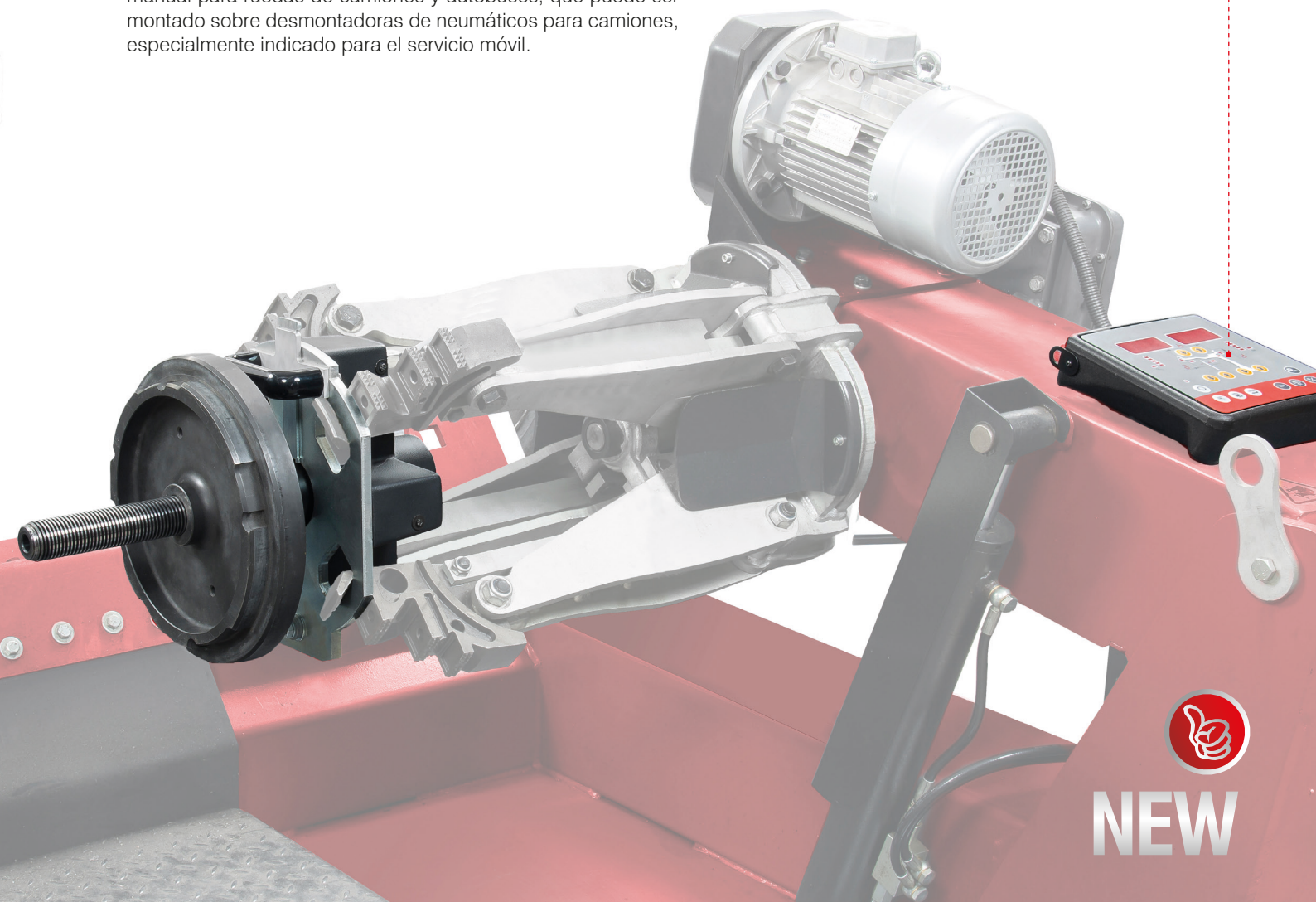

NEW

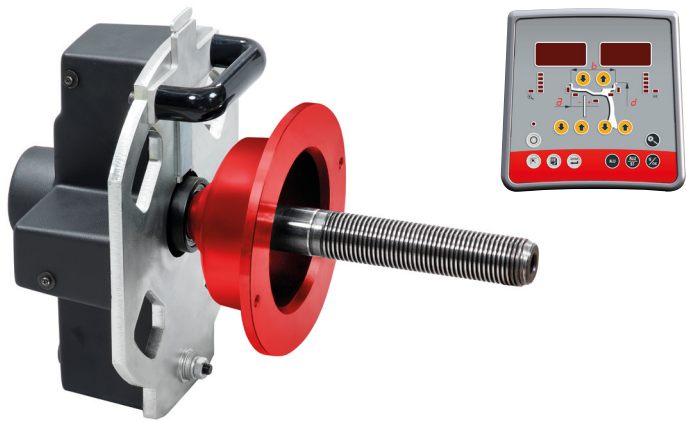

- Semplice e veloce sistema di fissaggio allo smontagomme
- Sistema manuale di lancio
- Display digitale portatile
- Alimentato tramite batterie ricaricabili con caricabatteria esterno (220 V AC, 12V CC, 24 V CC)

- Easy and quick mounting system on the tyre changer
- Manually operated spin system
- Digital portable display
- Powered by rechargeable batteries with external power supply (220 V AC, 12V CC, 24 V CC)
- Système de montage au démonte-pneus simple et rapide
- Système de lancement manuel
- Affichage digital portable
- Alimenté par une batterie rechargeable et un chargeur externe (220 V AC, 12 V DC, 24 V DC)
- Einfache und schnelle Befestigung an dem Montiergerät
- Manuelles Messlaufsystem
- Tragbares digitales Display
- Stromversorgung durch wieder aufladbare Batterie mit äußerem Ladegerät (220 V AC, 12V CC, 24 V CC)
- Sistema de montaje de los neumáticos sencillo y rápido
- Sistema de lanzamiento manual
- Indicador digital portátil
- Alimentado por batería recargable y cargador externo (220 V AC, 12 V DC, 24 V DC)

Accessori standard - Standard accessories - Accessoires standard - Standardzubehörteile - Accesorios estándar



STAND

- Supporto completo di alloggiamento per macchina, strumentazione e coni
- Storage stand complete with housings for machine, display and cones
- Support de rangement complet de logement pour machine, instrumentation et cônes
- Ständer zur Aufnahme von Gerät, Display und Konen
- Soporte completo con alojamiento por máquina, instrumentación y conos

Accessori opzionali - Optional accessories - Accessoires sur demande - Optionszubehörteile - Accesorios opcionales



TROLLEY KIT

- Kit trolley per supporto
- Trolley Kit for storage stand
- Kit chariot pour support de rangement
- Fahrbares Kit
- Kit trolley para soporte

SR 215/2



- Per centrare ruote con 8 fori su Ø 275 / 285,75 mm e con 10 fori Ø 225 / 285,75 / 335 mm
- To centre wheels with 8 holes on 275/285,75 mm Ø and with 10 holes on 225/285,75/335 mm Ø
- Pour des jantes à 8 trous sur Ø 275 / 285,75 mm t avec 10 trous sur Ø 225 / 285,75 / 335 mm
- Zur Zentrierung von 8-Loch-Rädern auf Ø 275 / 285,75 mm und 10-Loch-Rädern auf Ø 225 / 285,75 / 335 mm
- Para centrar ruedas con 8 orificios Ø 275 / 285,75 mm y con 10 orificios Ø 225 / 285,75 / 335 mm

CONE IV-V + GG DISC



- Per centrare ruote da autocarro e autobus con foro centrale Ø 202 / 221 / 281 mm mediante coni.
- To center truck or bus wheels with a central hole of 202 / 221 / 281 mm Ø by means of cones
- Pour centrer des jantes de poids lourdes et d'autobus avec un trou central de Ø 202 / 221 / 281 mm grâce à des cônes.
- Zur Zentrierung von LKW- und Autobusrädern mit Mittelloch Ø 202 / 221 / 281 mm mit Konen
- Para centrar ruedas de camiones y autobuses con orificio central Ø 202 / 221 / 281 mm mediante conos



CEMB
BALANCING MACHINES

CEMB S.p.A.
Via Risorgimento, 9
23826 Mandello del Lario (LC) Italy
www.cemb.com

Garage equipment division
CEMB - ITALY
Plant and Training Center
phone +39 0341 706369
fax +39 0341 700725
garage@cemb.com