

# KOMI

# sterfil



MOBILE COLUMN LIFT

# ST 1085 - ST 1100

Superior flexible solutions with an 8.5 ton or 10.0 ton lifting capacity



SMART CONTROL SYSTEM

**STERFIL**  
SUPERIOR SOLUTIONS

# Superior Solutions



The Stertil Group provides customised and technically advanced solutions for heavy-duty lifting requirements and loading bay equipment for customers worldwide, including the best possible service from skilled local partners. These superior solutions are conceived, developed and implemented by a team of professional specialists with unique expertise. Thanks to its quality people, its entirely in-house expertise and its international organisation, Stertil-Koni is the worldwide leader in the field of heavy-duty lifts.



## Wireless...

Our wireless mobile column lifts provide the ebright control solution for situations where the lifts need to be moved regularly. Using the innovative ID key, you can control up to 32 columns, each with a lifting capacity of 8.5 tons (ST 1085) or 10 tons (ST 1100) in a single setup. In most cases, the special deep cycle batteries only need to be recharged every two weeks. No time is wasted connecting up cables and the mechanic has maximum access to the vehicle, without any tripping hazard.

## ... or cabled, it's up to you

If you predominantly work in a fixed location the cabled mobile column lifts could be the best solution for you. This setup offers the possibility to connect up to 32 columns into a single configuration. The cabled versions also has a lifting capacity of 8.5 tons or 10 tons per column. Extra strong drive-over cables are optionally available for these cabled column lifts. All interconnection cables are equipped with heavy-duty plugs at both ends.

# Wireless mobile column lifts

## with **ebright Smart Control System**



TOUCH  
SCREEN



WIRELESS



Both the wireless and the cabled column lifts are equipped with a control panel on each individual column. Columns can be operated individually, in pairs or simultaneously as a complete set with the touch of a button. Each column can therefore be used at any given location.

### Full-colour touch screen control

The revolutionary **ebright Smart Control System** combines intuitive **ease of use** with maximum visual information about the lifting process. The main advantages:

- Touch screen control, works even when wearing gloves
- User-configured options, such as choice of language, safety warnings, scheduled maintenance
- Full-colour 7" screen, graphically highly attractive
- All relevant information available at a glance
- Customizable ID-Key to prevent unauthorized operation
- Wireless Mesh network for optimal connectivity





## Reliable hydraulic technology

- Long usable life of the column with minimal repair and maintenance due to reduced friction
- Stringent testing before leaving factory
- Manual lowering in case of a power outage
- Maximum protection of the cylinder and seal against damage

## Adjustable pick-up forks

ST 1085 mobile column lifts have a fork length of 350 mm and are therefore perfect for picking up a variety of vehicles even vehicles with super single tyres in a safe and secure manner. The fork length for the ST 1100 mobile column lift is 300 mm.

## Retractable wheels

Both the wireless and the cabled mobile column lifts are available with retractable wheels. This unique Stertil-Koni design is the best available on the market. This prevents high point loading on the floor and reduces the floor surface pressure by a factor of 10. The system is fast, efficient, very stable and extremely reliable.

## Adjustable lowering speed

Do you want to lower the vehicle more slowly, so that you have more control when lowering onto axle stands? This is easily done at the high resolution touch screen.



## Simple recharging

The wireless columns are easy to charge by means of a 230 V wall socket. Cabled mobile columns operate from a standard 400 V supply with other voltages available.

## Fast lifting and lowering

The ST 1085 and ST 1100 reach their maximum lifting height of 1,850 mm in just 94 seconds, making them one of the fastest mobile column lifts in the world.

# Well thought out in all aspects



**32  
MAX**

MAX 32 LINKED  
COLUMNS



ADJUSTABLE  
LOWERING SPEED



OVERLOAD  
PROTECTION



UNIQUE  
SYNCHRONISATION  
SYSTEM

## Easy to move

Stertil-Koni mobile column lifts really are 'mobile'. Thanks to the synthetic wheels and hydraulic pallet truck mechanism with patented overload protection, the column is easy to move.

## Safe working space

As an extra safety feature, we have also designed ample working space between the column and the vehicle. Even if there is a problem with the air suspension, the vehicle should not come into contact with the column.

## Unique synchronisation

The synchronisation system is activated at a height difference of just 15 mm. This ensures a safe and smooth-running lifting and lowering cycle, even in cases where the distribution of the vehicle load is extremely uneven.

## Lifetime guarantee

The innovative synthetic runner wheels within the column come with a lifetime parts guarantee.





○ High resolution 7" touch screen

○ Intuitive controls



## ebright Features

SMART CONTROL SYSTEM

- High resolution 7" touch screen
- Owner/User configurable system with user ID key
  - Individual user settings for setting language and units
  - Protection against unauthorized use due to personalised ID key
- Maintenance notifications
- Visual display of maximum programmable lifting height if set
- Warning & failure information
- Operation manual on-screen available if required
- Tracking of specific operations and information codes
- Intuitive controls with actual data about the lift:
  - Indication for Single, All or Pair operation mode
  - Information about how many columns are in the set (up to 32 columns)
  - Actual lifting height displayed
  - Lowering speed can be manually adjusted on the touch screen
  - Battery status information
  - Customizable ID-Key to prevent unauthorized operation
- Wireless Mesh network with continuous active channel search offering optimal connectivity

# Everything under control



Overview of ST 1085 – ST 1100 models	ebright wireless ST 1085-FWA ST 1100-FWA	ebright wireless ST 1085-RWA ST 1100-RWA	ebright cabled ST 1085-FSA ST 1100-FSA	ebright cabled ST 1085-RSA ST 1100-RSA
ebright Smart Control System with a control box on each individual mobile column	●	●	●	●
Touch screen with important information about the system e.g. lifting height, operation mode	●	●	●	●
Wireless Mesh network with continuous active channel search offering optimal connectivity	●	●		
These columns utilise a power outlet in the workshop and communicate with each other via interconnecting cables			●	●
Adjustable lowering speed for slow or normal lowering	●	●	●	●
Hydraulic pallet truck mechanism with patented overload protection	●	●	●	●
350 mm adjustable fork, suitable for super single tyres	ST 1085	ST 1085	ST 1085	ST 1085
300 mm adjustable fork	ST 1100	ST 1100	ST 1100	ST 1100
Fixed synthetic wheels that reduce the floor surface pressure	●		●	
Retractable synthetic wheels integrated into the base frame, for 10x less surface pressure		●		●

## Technical specifications

- Lifting capacity: 8,500 kg or 10,000 kg  
 Lift system: hydraulic lifting system with micro-processor-controlled synchronisation  
 Lifting height: maximum 1,850 mm, automatic stop at the highest position  
 Lifting time: 94 seconds  
 Motor rating: 2.2 / 3.0 kW per column (Cabled / Wireless)  
 Weight: 615 kg per column (Wireless)  
 Column lift height: 2,465 mm

## Highest safety requirements

- ANSI/ALI-ALCTV certified (USA), CSA certified (Canada), CE certified (Europe).
- Independent mechanical locking system engages at 125 mm above floor level. Locking pawl engaged by gravity. The locking system is always active, even when the column is turned off.
- Locking profile with locking increments of just 35 mm.
- Synchronisation between the mobile lifting columns starts at a height difference of 15 mm.
- Automatic overload protection.
- Low voltage control panel.
- Each column is equipped with an emergency stop.
- Each individual mobile lifting column is tested prior to leaving the factory.
- Splash-proof electrical system (IP 65).

## Accessories & options

Stertil-Koni offers an extensive package of accessories & options tailored to fit your specific needs.

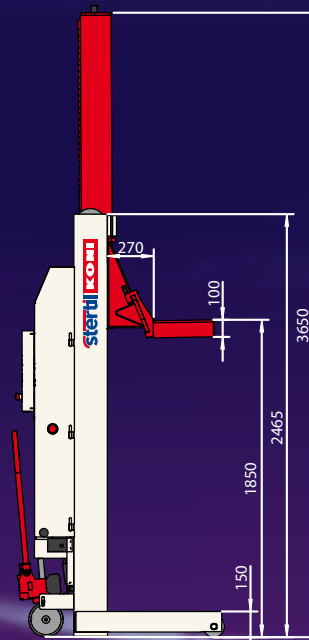

Fixed front wheels

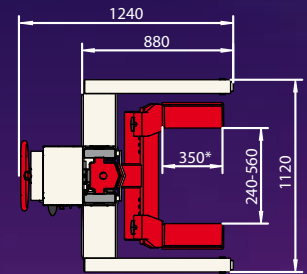

Adjustable forks

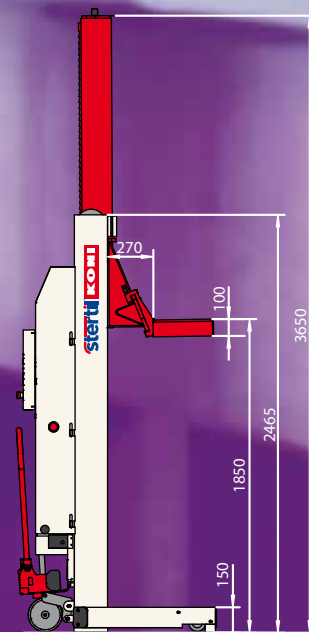

Retractable front wheels

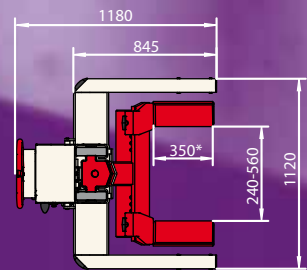

Adjustable forks

\* For the ST 1100:  
300 mm

## More information?

For more information about the ST 1085, ST 1100, or any of Stertil-Koni's other top products, please do not hesitate to contact us. We will be pleased to assist you.



Stertil B.V.  
 P.O.Box 23  
 9288 ZG Kootsterille  
 The Netherlands  
 Tel. +31 (0)512 334444  
 www.stertilkoni.com  
 info@stertilkoni.nl  
 Stertil-Koni  
 @Stertil

a member of the Stertil Group