

At this time Hunter Engineering Company does not offer motorcycle adaptors for wheel balancing

Contact Haweka for additional application

Motorcycle Clamping Device ProBike II - Series 805



HAWEKA USA Inc.

150 Parkway West ♦ Duncan, SC 29334

Phone (866) 442 9352

www.haweke-usa.com ♦ info@haweke-usa.com

Motorcycle Clamping Device



Modular System STANDARD

Now also includes possibility for Scooter wheels

Wider clamping range, now for 10" rims

With the ProBike STANDARD system, you are now able to balance a great variety of motorcycle wheels. The new system is a further development of the former 802 series Kit. It now also includes an adaptor board and the new QuickFix (Ø 14 mm) Clamping device. The new adaptor board is smaller and requires less space. It can be upgraded with the adaptor board PROFESSIONAL.



Depending on the balancer there are two different types of adaptors available to install the system to the machine. The necessary adaptor has to be selected when purchasing the system.

- centering cones
- 14 mm motorcycle shaft
- centering sleeves 15 - 28 mm
- QuickFix Ø 14 mm
- Adaptor board Standard

Modular System PROFESSIONAL

The ProBike Standard can be upgraded with the modular system PROFESSIONAL.

It has become more individual in handling and offers the possibility to balance even more mono lever motorcycle wheels. New in this kit is the QuickFix for 19 mm motorcycle wheels. A newly designed adaptor board is part of this kit.



- Upgrade Kit for Monolever Wheels
- 19 mm motorcycle shaft
- centering sleeves up to 35 mm
- special centering kits for mono lever wheels
- QuickFix Ø 19 mm
- Adaptor board professional

Modular System EXPERT

With the Pro Bike modular system **EXPERT**, you are the expert in balancing motorcycle wheels. The additional motorcycle shafts included in this kit will give you perfect balancing results.

The kit includes a hanging bracket which can easily be fixed to the adaptor board included in the modular system professional.

So the additional shafts can be stored efficiently and without getting dirty.



Upgrade Kit Motorcycle Shafts

- 9 additional motorcycle shafts (Ø 10, 12, 15, 16, 17, 20, 22, 25, 28 mm)
- distance sleeves in different diameters and length

Part Numbers:

Modular System STANDARD

Balancer	HAWEKA Part Number
GSP 9700	805 818 000
DSP 7700	805 818 000
DSP 9000	805 400 000
DSP 9200	805 400 000
DSP 9500	805 400 000
DSP 8500	805 400 000

Modular System PROFESSIONAL

Balancer	HAWEKA Part Number
GSP 9700	805 818 001
DSP 7700	805 818 001
DSP 9000	805 008 001
DSP 9200	805 008 001
DSP 9500	805 008 001
DSP 8500	805 008 001

Modular System EXPERT

Balancer	HAWEKA Part Number
GSP 9700	805 818 002
DSP 7700	805 818 002
DSP 9000	805 008 002
DSP 9200	805 008 002
DSP 9500	805 008 002
DSP 8500	805 008 002

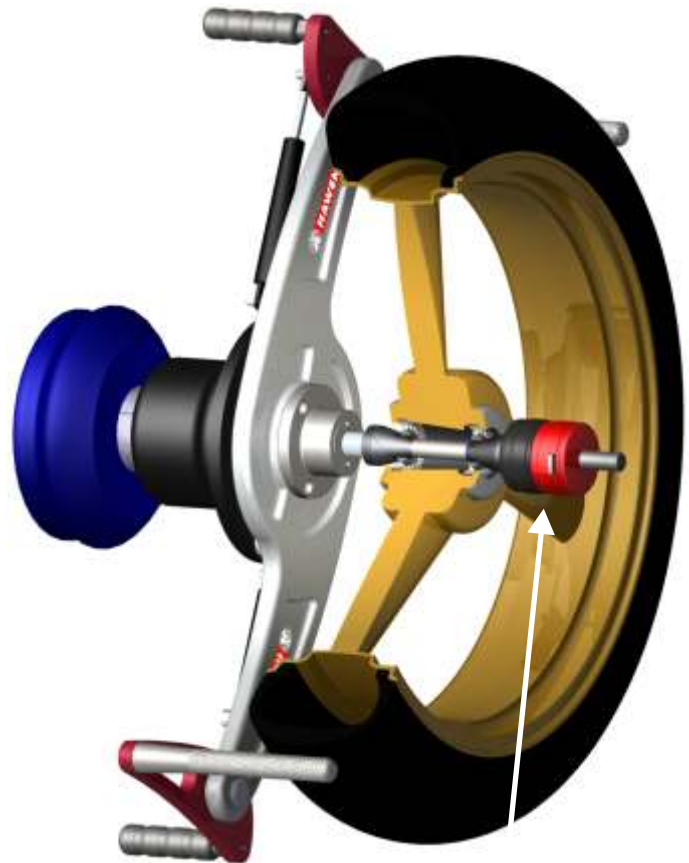

QuickFix	HAWEKA Part Number
Ø 140 mm	890 140 001
Ø 190 mm	890 190 001

Modular System - ProBike II



Special Centering Kits

You now own the ProBike modular STANDARD, and want to balance motorcycles with mono lever wheels. In this case you will need the modular system PROFESSIONAL, in which all the special centering adaptors are included. Should you require only one special centering adaptor, this can also be purchased individually.

APRILIA

RST Futura

BMW

F 650 CS Scarver

For rear wheels

1 x Centering Kit: P/No. 860 190 012



BMW

R 850 C, R, GS

R 100 Mystic

R 100 R, RT, PD Classic

R 1100 GS

R 1100 R, S, RT, RS

R 1150 GS, RT

R 1150 GS Adventure

R 1150 R Rockster

R 1200 C

R 1200 C Independent

For rear wheels

1 x Centering Kit: P/No. 860 141 005

R 1200 GS
K 75 RT
K 1100 LT, RS
K 1200 GT, LT, RS

Shaft \varnothing 14 mm



DUCATI

(Three Spoke Rim)

748

748 BIPOSTO

916

916 BIPOSTO

(Five Spoke Rim)

748 R

748 S

996 (all types)

998 (all types)

For rear wheels (to be used face and back!)

1 x Centering Sleeve: P/No. 860e190 004*

TRIUMPH

Sprint ST

Speed Triple

Daytona 955 i

T 509



MV AGUSTA

F4 750

750 Brutale

VFR V-TEC

For rear wheels (to be used face and back!)

1 x Centering Sleeve: P/No. 860e190 011*

HONDA

VFR 750

VFR 800



For front wheels **MV AGUSTA**

1 x Set of Centering Sleeves:

P/No. 860 190 350



In order to use any of the special adaptors, a 19 mm motorcycle shaft and the 19 mm QuickFix are required! They are included in the Professional Upgrade Kit.

Part No. = 890 190 001 QuickFix 19 mm

Shaft depending on type of balancer:

Part No. 870e010 190 = cylindrical attachment

Part No. 870e997 190 = conical attachment

Part No. 850e190 001 Pressure Piece for Kits with *

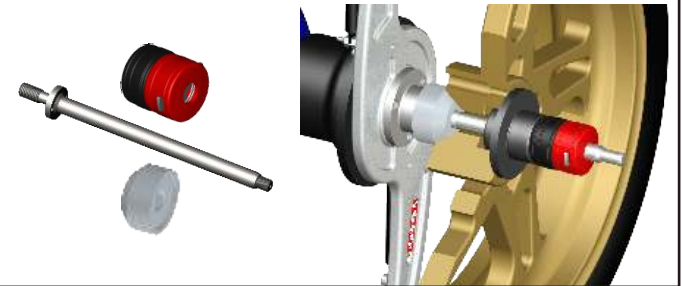

HARLEY DAVIDSON

Bad Boy

Heritage Springer

Dyna Super Glide

Softail Deuce

Softail Standard

Dyna Wide Glide

Softail Springer

Sportster 883 ST

Sportster1200Custom

Sportster 1200 Sport

Sportster 1200

For front and rear wheels

1 x Set of Spacers: P/No. 860 190 007

Fat Boy

Heritage Softail Classic

Dyna Glide Low Rider

Softail Custom

Night Train

Dyna Glide Conv.

Electra Glide Classic

Sportster 883 Hugger



HARLEY DAVIDSON

V-Rod

For front and rear wheels

1 x Set of Centering Sleeves: P/No. 860 190 014



SUZUKI

GSX-R 600

GSX-R 750

GSX-R 1000

GSX R 1300 HAYABUSA

For front and rear wheels

1 x Set of Centering Sleeves: P/No. 860 190 009



SUZUKI

GSF 1200 Bandit

For rear wheels

1 x Set of Centering Sleeves: P/No. 860 190 240



HONDA

Goldwing 1800

NTV 650

For rear wheels

1 x Centering Sleeve: P/No. 860e190 008*

