

Biglift 2.50 Saa

Electro-hydraulic twin-ram lift, 5 t with superstructure with arms

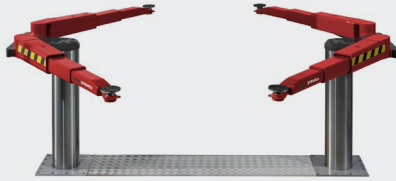

Application

- Repairs and maintenance
- Body work

Approvals / recommendations

- Renault
- Saa 265: Mercedes-Benz

Description:

Steel cassette:

- Waterproof steel cassette

Hydraulic unit:

- Hard-chrome plated cylinder
- Flexible synchronization and safety system
- Corrosion-free guiding elements
- Pump unit with immersed motor
- Hydraulic oil
- Pneumatic emergency lowering
- Programmable pushbutton control unit
- Great stability, even with uneven weight distribution; due to the cylinder diameter of 213 mm

Superstructure:

- Double telescopic arms
- Internal arm locking system
- Low minimum height

Saa 265:

- Mechanical ratchet system integrated in the hydraulic unit
- Air preparation unit for oiled and regulated compressed air (min . 6 bar / max . 10 bar)

Standard colours:

- Base plate: RAL 7016 - grey
- Arms: RAL 3020 - red

Versions:

- Saa 230 & Saa 265

Steel cassette:

- Zinc-coated
- Coated
- Self-carrying (Saa 230)

Installation:

- Superstructure on floor
- Superstructure in floor with covers (Saa 230)
- Ceiling installation (Saa 230)

Optional extras:

- Large program of extra pads

Zinc coating and special colours on request!



Scan the QR-Code for detailed product information.

Further Information on www.autopstenhoj.com

autop Maschinenbau GmbH

Sandkampstraße 90
48432 Rheine | Germany

☎ +49 5971 8602-02

📠 +49 5971 8602-25

✉ info@autopstenhoj.com

STENHØJ A/S

Barrit Langgade 188-190
DK-7150 Barrit

☎ +45 76 82 13 30

📠 +45 76 82 13 31

✉ info@autopstenhoj.com

Technical data	
Lifting capacity	5,000 kg
Lifting height	1,865 mm
Working height	2,005 – 2,065 mm
Cylinder diameter	2 x 213 mm
Distance between cylinders	Saa 230: 2,150 mm Saa 265: 2,650 mm
Lifting / lowering time (high pressure)	approx. 45 sec.
Foundation depth	2,625 mm
Pump unit	3 kW
Hydraulic oil	18 l
Voltage	230 / 400 V – 50 Hz – 16 A

Platforms	
Total width	2,950 mm
Lifting pad included in the delivery	11028 (135 – 195 mm)
Min. height	135 – 195 mm
Drive-through width	Saa 230: 1,930 mm Saa 265: 2,430 mm
Arm length, min. - max.	715 – 1,410 mm

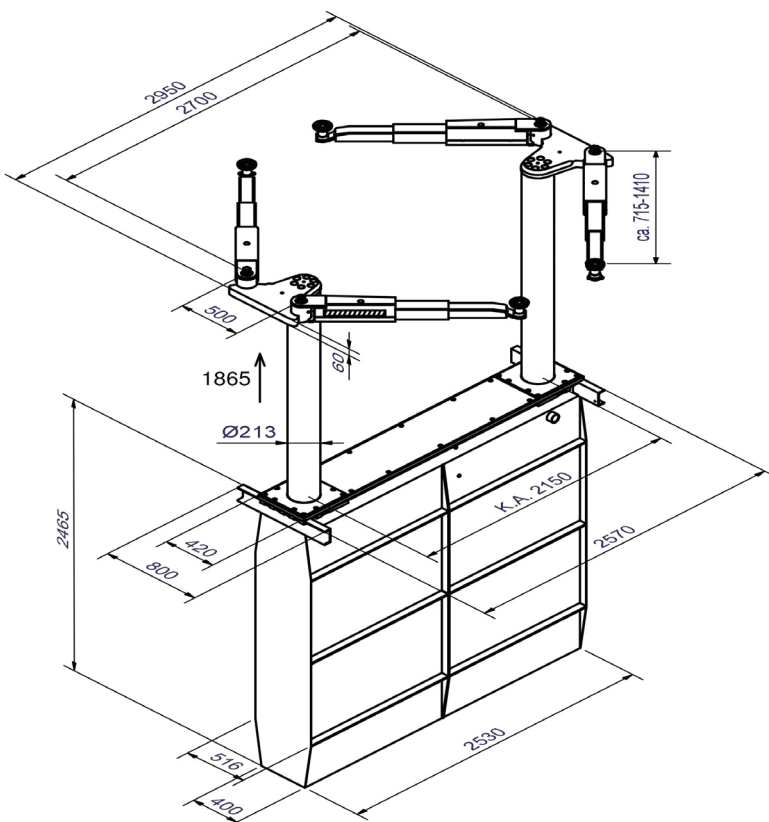

Superstructure on floor



Superstructure with lifting pads and wheel adaptors

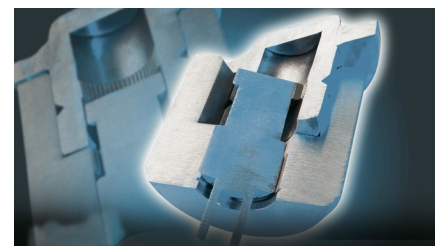

Internal arm locking system