

GSP9600HD

ForceMatch® Heavy-Duty Wheel Balancer

Also handles
most passenger
car and light
truck wheels



HUNTER
Engineering Company

ForceMatch
GSP9600HD



GSP9600HD

HUNTER

HammerHead

Featuring

SmartWeight®
Balancing Technology

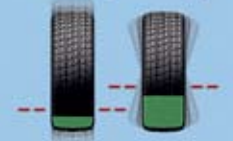

HUNTER
Engineering Company

GSP9600HD ForceMatch® Wheel Balancer

The GSP9600HD Quickly Measures Runout With *EVERY* Balance!

The Hunter GSP9600HD wheel balancer uses loaded roller contact to measure runout (eccentricity) of a tire and rim assembly and eliminate wheel-related vibration.

The fastest and most reliable method to measure runout is with a loaded roller system, which provides contact across the footprint of a tire's surface to detect if a tire and wheel assembly are out of round.



The GSP9600HD's loaded roller provides the fastest and most accurate runout measurement.

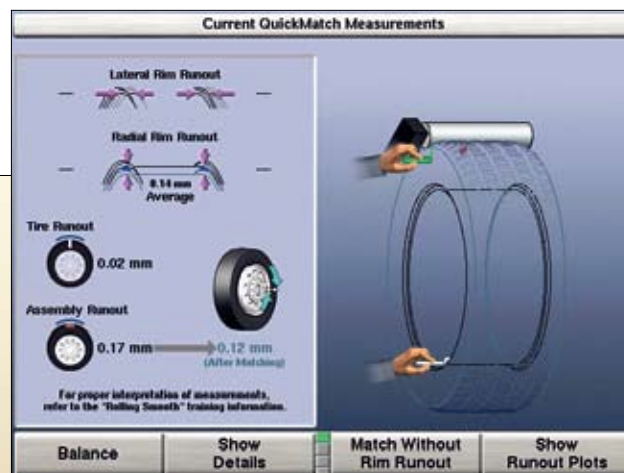

The match-mounting feature on the GSP9600HD tells the technician exactly how to rotate the tire on the rim to minimize vibration.



Exclusive Features Make Expert Balancing Easier and Faster

Find True Assembly High Spots

The GSP9600HD computes and locates the true first-harmonic assembly high spot. The machine then automatically positions this high spot to top dead center position to be marked by the operator for future reference.

A marked wheel can be properly mounted, taking into account the mounting position of the wheel's high spot in relation to the other wheels on the truck. In most dual wheel assemblies, high spots are mounted opposite one another to maximize tire wear and ride quality.

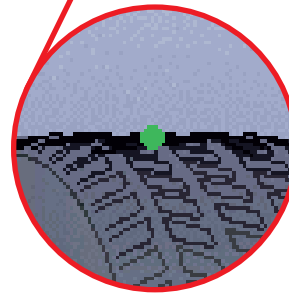

Match Assembly Diameters

The GSP9600HD automatically measures the wheel assembly diameter with every balance. With this information, operators can match dual wheels and drive tires on common axles with similar diameter wheel assemblies to improve tire life and prevent uneven wearing and damage.

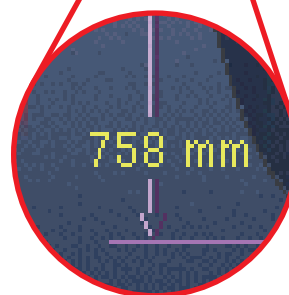

If wheel assemblies are being built to be stored for later use, the diameter can be written on the tire sidewall and later paired with a similar wheel.

Exclusive Features Make Expert Balancing Easier and Faster

Balance any size wheel

Sharing many of the same features as other Hunter balancers, the GSP9600HD is able to accommodate passenger-car and light-truck wheels as well as heavy-duty wheel assemblies, making it one of the most versatile balancers on the market.

With the same size balancer shaft, all current Hunter cones and adaptors can be used on the GSP9600HD.

The GSP9600HD also includes two separate CenteringCheck® software features to ensure proper mounting of wheels. One procedure accommodates light-and medium-duty applications the other accommodates heavy-duty applications.

*Also handles
most passenger
car and light
truck wheels*



Integrated Wheel Lift - Standard

The integrated wheel lift easily lifts the heaviest wheel assemblies for effortless mounting on the balancer. Convenient hand controls allow the operator to lift and position the wheel on the balancer shaft. Built-in rollers on the wheel trolley glide the wheel into proper position.



Roll the wheel on...



press the 'Raise' lever...



slide the wheel on...



lock the wheel in position.

Dataset® Arms Speed Start-to-Finish Cycle Time

Inner Dataset® Arm



Inner Dataset® arm determines exact placement for weights and automatically measures weight positions on rims with diameters up to 30 in. (762 mm).

Automatic Double Dataset® Arms



Inner and Outer Dataset® arms speed wheel data direct-measure input and placement of clip-on or adhesive weights, increasing accuracy and allowing more single-spin balances on light-vehicle and heavy-duty steel rims.

Automatic Weight Mode and Location Detection**

This feature eliminates the need for the operator to select balance modes, reducing service time and possible mode entry errors. Balance mode is selected automatically based on the weight position chosen.

When the technician places the Dataset® arm...

... DOWN inside the wheel, the balancer automatically selects "Tape-Weight Mode".



... UP on the wheel, the balancer automatically selects "Clip-Weight Mode".



Rim Scan Feature**

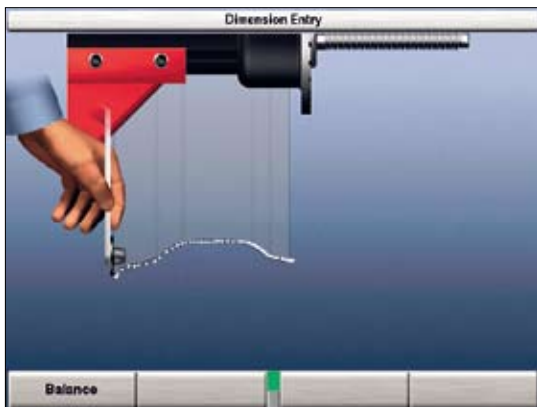

Using the Inner Dataset arm as a guide, Rim Scan traces the exact wheel contour and stores the scanned distances and diameters for all available tape-weight locations selected by the operator. Rim Scan also offers the benefits of Automatic Weight Positioning to increase the capability to single-spin balance with SmartWeight® technology.

Patch Balance® Feature



The perfect choice for heavy-duty wheel assemblies and oversized custom wheel assemblies. With 4x4 and street cruiser tire weights growing in size, the Patch Balance® feature solves excessive weight balance problems by using weighted patches inside the tire. Rim-mounted weights can be reduced or eliminated. Increase profits by balancing oversize tires that others turn away.

SmartWeight® Balancing Technology

Hunter Engineering's patented SmartWeight® balancing technology minimizes correction weight usage and maximizes productivity over conventional static and dynamic methods.

On passenger car and light-truck applications, SmartWeight balancing can cut wheel weight costs 30% to 40%, reduce service time with more single-spin balances, and improve vehicle ride quality.

In heavy-duty applications, SmartWeight balancing improves the ride quality over typical static balancing practices used in on-the-vehicle balancing applications. Today's lighter axles, wheel combinations and frame rails can also benefit from the reduction of couple (shimmy) forces not corrected with any type of static balancing procedure.



Unique Benefits:

- ✓ **Cuts light-vehicle wheel weight costs 30% to 40%**
- ✓ **Significantly reduces labor costs and service time**
- ✓ **Automatically performs a better overall balance**
- ✓ **Simplifies balancer use**
- ✓ **Eliminates shortcuts that affect quality**

Servo Stop and Servo Push Drive Control*



- ✓ Servo Stop feature automatically rotates and holds the wheel at top-dead-center or bottom-dead-center locations.
- ✓ Servo Push feature rotates the wheel to the next weight placement position at the push of the wheel.

Save Labor Time on More Than 30% of Balances!

SmartWeight technology typically reduces "start-to-finish" cycle time on more than 30% of wheels balanced by using a single wheel weight to achieve the best possible static and couple balance.



**Typical Correction
Double Weight**

**SmartWeight Correction
Single Weight**

For more information on SmartWeight balancing technology, visit our website at www.weightsaver.com

BDC Adhesive Weight Placement Laser



- ✓ A Bottom Dead Center (BDC) laser line automatically identifies the BDC position for fast adhesive-weight application.
- ✓ Helps guide operator to optimal location for correct weight placement.

HammerHead™ TDC Clip-Weight Placement Laser System

The patented HammerHead™ TDC weight placement laser system projects laser lines onto the inner and outer top-dead-center of the wheel to indicate the proper clip-weight positions. Even slight misplacement of a wheel weight lead to an inferior and time-consuming balance with excessive checkspins.

When performing ForceMatch match-mounting operations, the HammerHead system also indicates the assembly high spot.

The HammerHead system increases accuracy, productivity and shop profitability, resulting in more single-spin balances and superior ride quality.

The HammerHead system is an optional feature of the GSP9600HD and can be added by ordering part number 20-2288-1.



Optional HammerHead™ printer and shelf shown here.

Clip-Weight Placement



Angle errors from even slight misjudgment of the TDC location lead to an inferior and time-consuming balance with excessive checkspins.



Precision wheel weight placement is fast and easy using the HammerHead TDC laser as a guide.

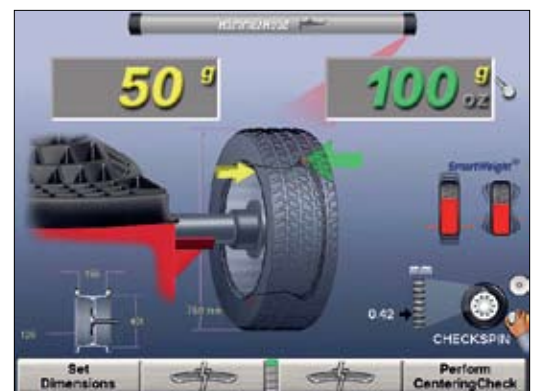

Top-dead-center laser lines are projected onto the rim flange to show the proper wheel weight position or assembly high spot.

Specifications

Power Requirements: 230V (+10%-15%), 1.3 amp, 50/60 Hz, 1-phase

Capacity:

- Rim Width: 1.5 in. (38 mm) to 16 in. (406 mm)
- Rim Diameter: 10 in. (254 mm) to 30 in. (762 mm)
- ALU: 7.5 in. (191 mm) to 30 in. (762 mm)
- Automatic Inner Dataset® Range: 10 in. (254 mm) to 30 in. (762 mm)
- Maximum Tire Diameter: 52 in. (1,321 mm)
- Maximum Tire Width: 19.8 in. (503 mm)
- Maximum Tire Weight: 500 lbs. (227 kg)
- Minimum Tire Diameter for Roller Application: 26 in. (660 mm)

*Note: Tires less than the minimum diameter can be balanced but not ForceMatched.
No assembly diameter or runout information provided under a 26 in. diameter.*

Imbalance Resolution: +/- 0.05 oz. or 1 gm

Placement Accuracy: 512 positions (+/- 0.7 degrees)

Balancing Speed: 100 RPM

Motor: "Intelligent" programmable drive system and DC motor

Air Requirements: 100-175 psi (7 ± 12 bar)

Shipping Weight: 1,070 lbs. (486 kg)

** Some dimensions, capacities and specifications may vary depending on model, tire and wheel configuration.*



Heavy-Duty Adapters:



20-2274-2
Heavy-Duty & Bus,
8-10 Lug



20-2275-2
Commercial Truck & Van,
8-10 Lug

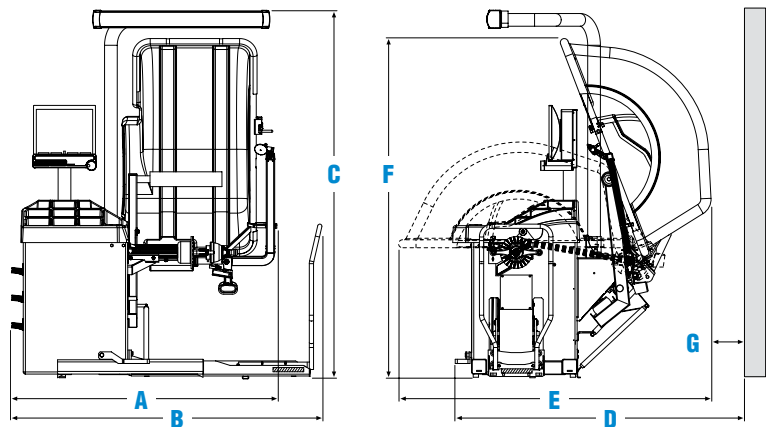

GSP9600HD Dimensions

- A** 59.4 in. (1,509 mm)
- B** 68.6 in. (1,742 mm)
- C** 86.1 in. (2,187 mm)
- D** 70.4 in. (1,788 mm)
- E** 73 in. (1,854 mm)
- F** 81 in. (2,057 mm)
- G** 10 in. (254 mm)



LASER LIGHT
DO NOT STARE INTO THE BEAM OR VIEW
DIRECTLY WITH OPTICAL INSTRUMENTS
CLASS 2M LASER PRODUCT

LASER LIGHT
DO NOT VIEW DIRECTLY
WITH OPTICAL INSTRUMENTS
CLASS 1M LASER PRODUCT

Because of continuing technological advancements, specifications, models and options are subject to change without notice.

CenteringCheck, Dataset, HammerHead, Quick Cal-Check, Quick-Thread, ServoDrive, SmartWeight, Spindle-Lok, and Split Spoke are trademarks of Hunter Engineering Company.

HUNTER
Engineering Company

www.hunter.com

