

RAV635.1-635.2-635.3-635.4
RAV635.11-635.21-635.31-635.41

3500 kg

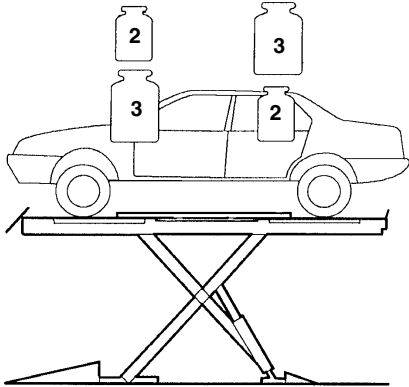

RAV640.1-640.2-640.3-640.3.46-640.4-640.4.46-640.5-
RAV640.6

RAV640.11-640.21-640.31-640.3.461-640.41-640.4.461-
RAV640.51-640.61

4200 kg

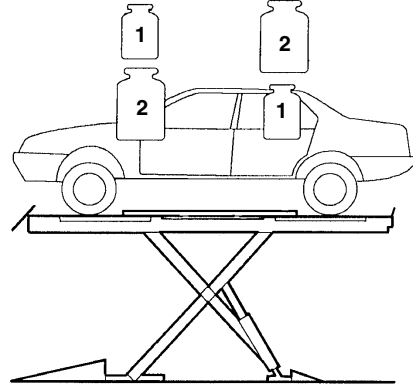

RAV650.1-650.2-650.3-650.4-650.5-650.6
RAV650.11-650.21-650.31-650.41-650.51-650.61

5000 kg

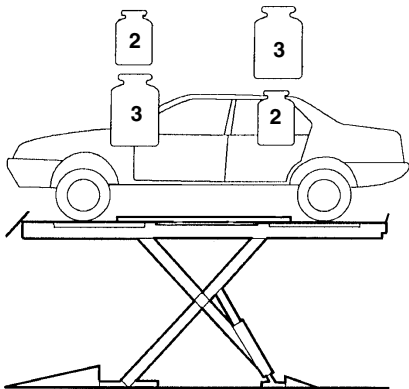

RAV660.1-660.2-660.3-660.4-660.5-660.6
RAV660.11-660.21-660.31-660.41-660.51-660.61

6000 kg

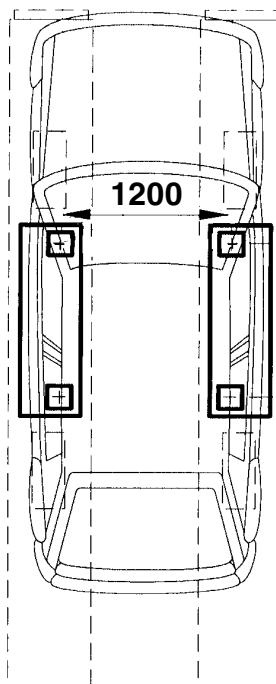
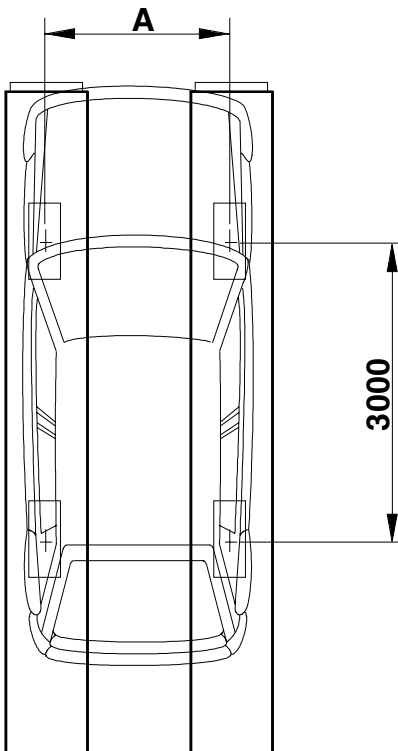
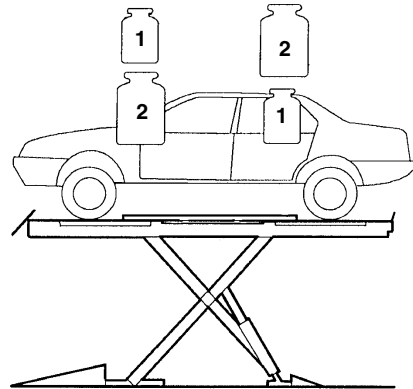

RAV635.1-635.2
RAV635.3-635.4
RAV635.11-635.21
RAV635.31-635.41

RAV640.1-640.2-
RAV640.3-640.4-
RAV640.3.46-640.4.46-
RAV640.5-640.6
RAV640.11-640.21-
RAV640.31-640.41-
RAV640.3.461-640.4.461-
RAV640.51-640.61-

RAV650.1-650.2-
RAV650.3-650.4-
RAV650.5-650.6
RAV650.11-650.21-
RAV650.31-650.41-
RAV650.51-650.61

RAV660.1-660.2-
RAV660.3-660.4-
RAV660.5-660.6
RAV660.11-660.21-
RAV660.31-660.41-
RAV660.51-660.61

A 1600

1700

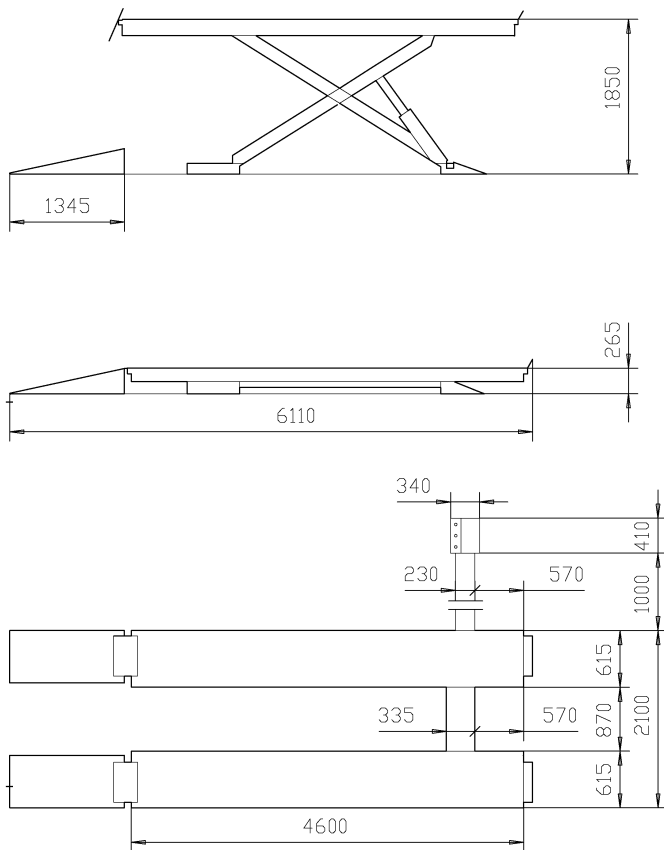

RAV635.1

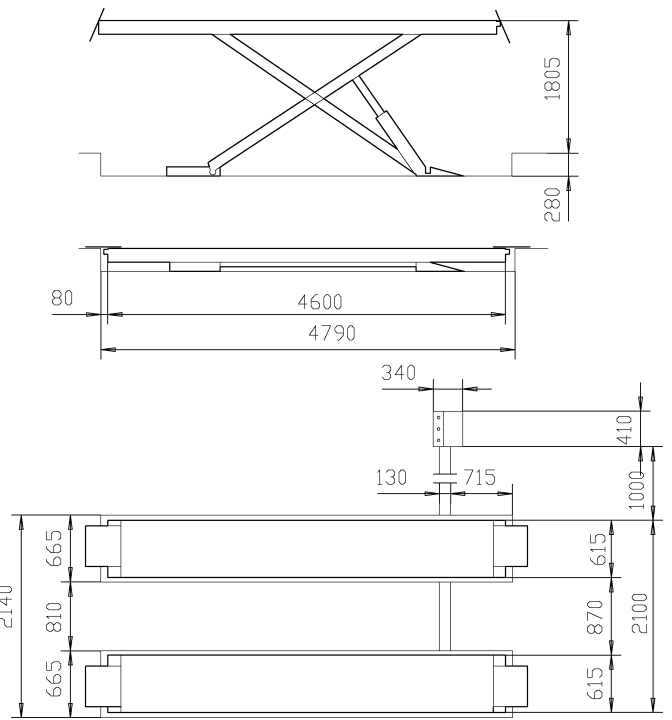

RAV635.1 I

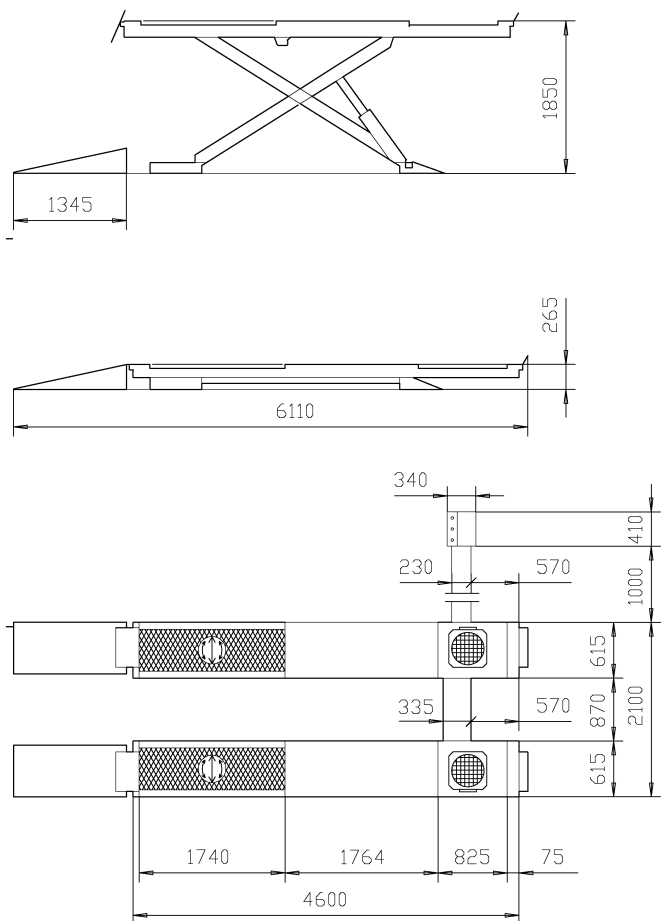

RAV635.2

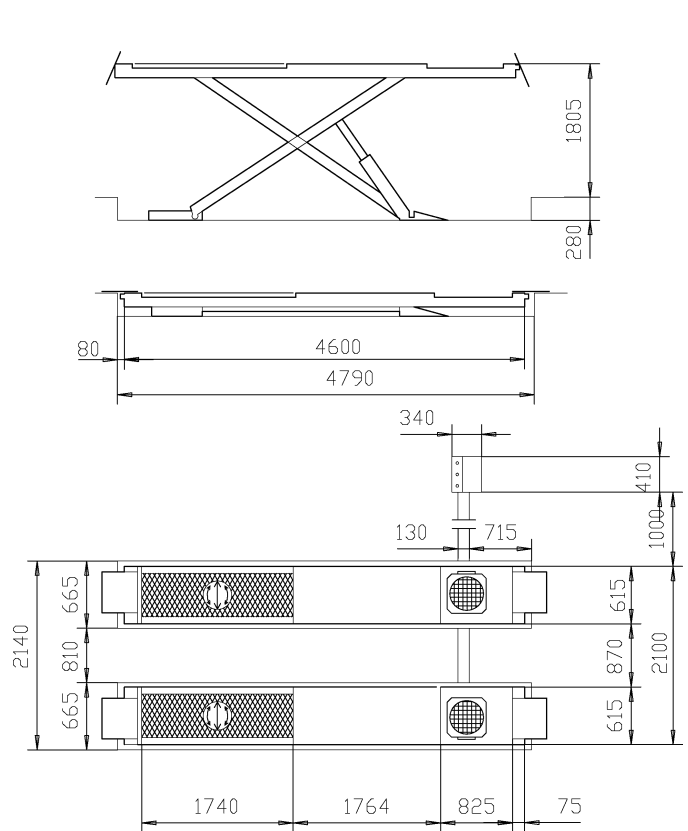

RAV635.2 I

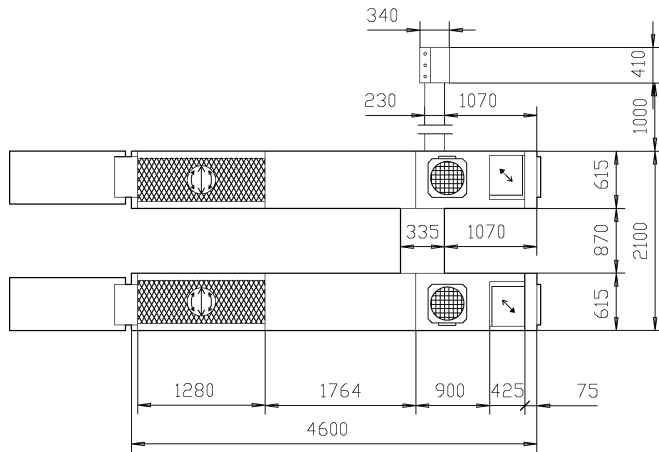
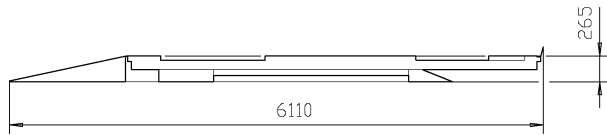
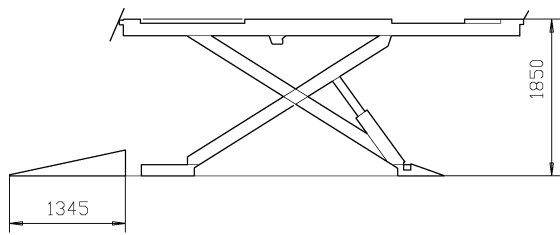

RAV635.3

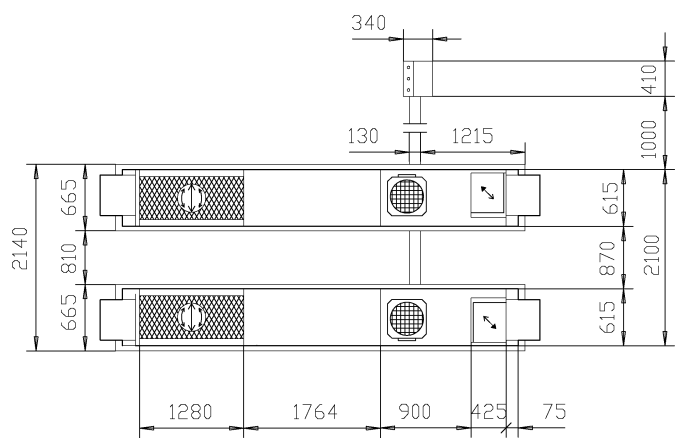
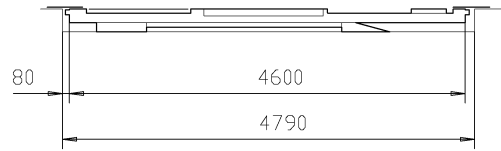
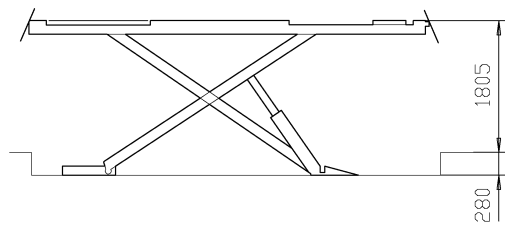

RAV635.3 I

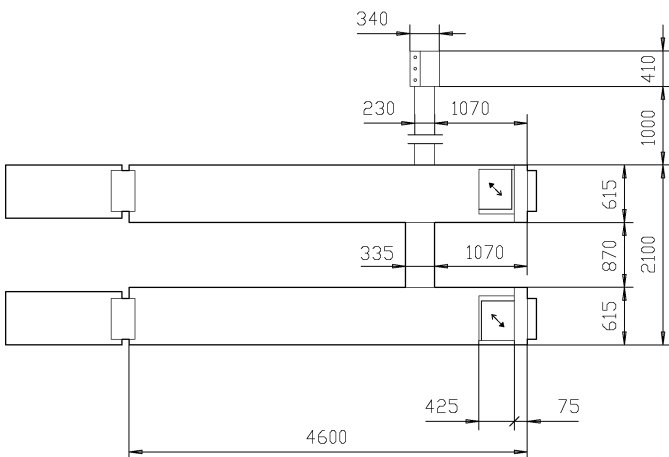
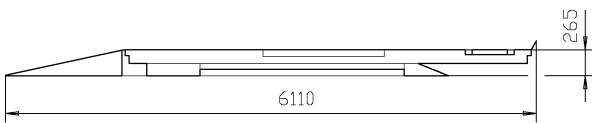
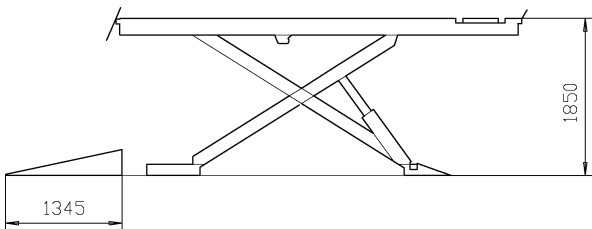

RAV635.4

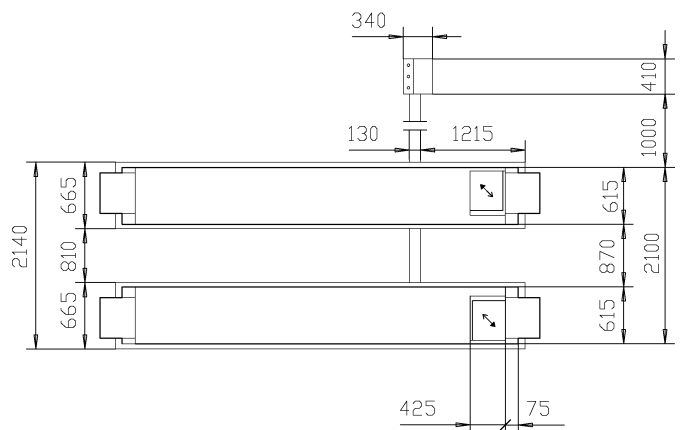
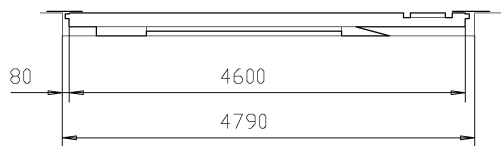
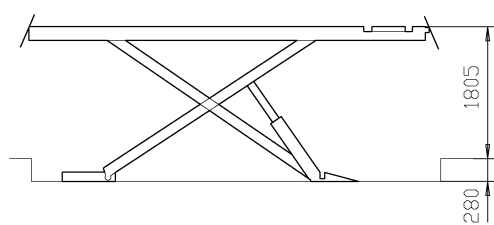

RAV635.4 I

DATI TECNICI - TECHNICAL DATA RAV635			
CARATTERISTICHE TECNICHE	SPECIFICATIONS	VERSIONE A PAVIMENTO FLOOR LIFT	VERSIONE AD INCASSO RECESSED LIFT
Portata sollevatore (kg)	Lift capacity (kg)	3.500	3.500
Motore (kW)	Motor (kW)	2,6	2,6
Tempo salita sollevatore (") (con carico massimo)	Lift elevation time (") (with maximum charge)	34	40
Tempo discesa sollevatore (") (con carico massimo)	Lift downward movement time (") (with maximum charge)	26	31
Peso (kg) RAV635.1 - RAV635.4	Weight (kg) RAV635.1 - RAV635.4	1.450	1.375
Peso (kg) RAV635.2 - RAV635.3	Weight (kg) RAV635.2 - RAV635.3	1.700	1.625
Rumorosità dB(A)	Noise level dB(A)	≤ 70	≤ 70
Pressione aria (bar)	Air pressure (bar)	Min.6 - Max.10	
Pressione olio max. centralina idraulica (bar) RAV635.1 (I) - RAV635.2 (I)	Hydraulic control box max oil pressure (bar) RAV635.1 (I) - RAV635.2 (I)	270	
Pressione olio max. centralina idraulica (bar) RAV635.3 (I) - RAV635.4 (I)	Hydraulic control box max oil pressure (bar) RAV635.3 (I) - RAV635.4 (I)	230	

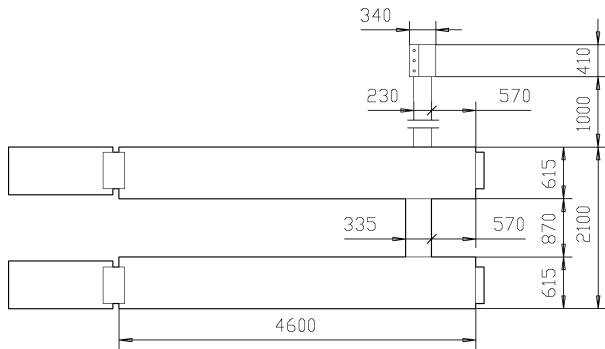
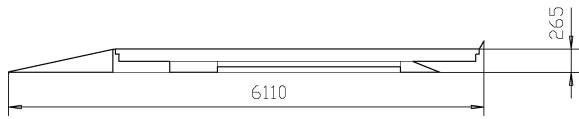
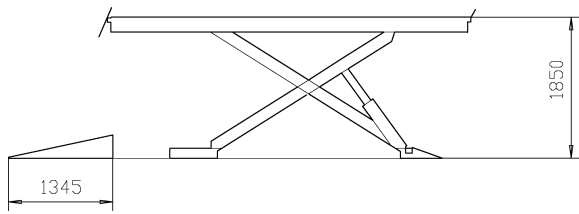

RAV640.1

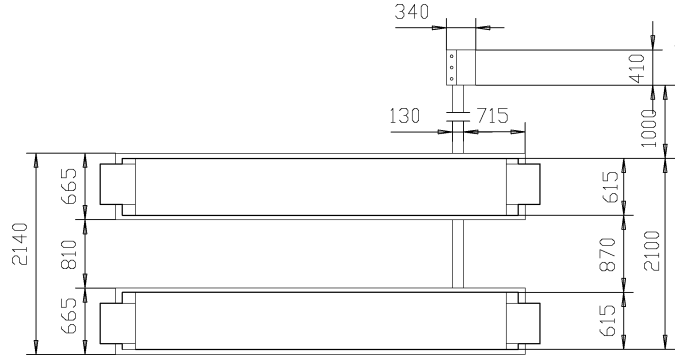
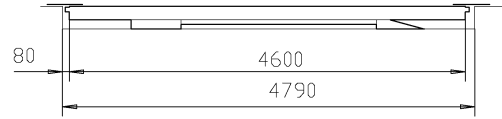
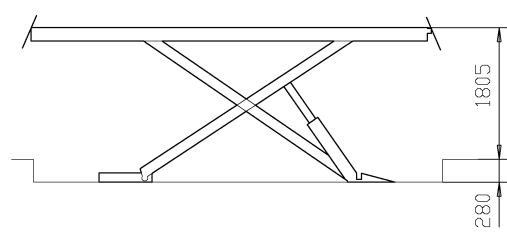

RAV640.1 I

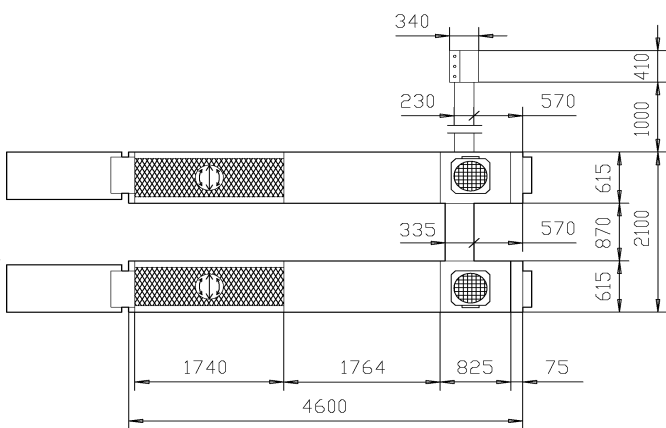
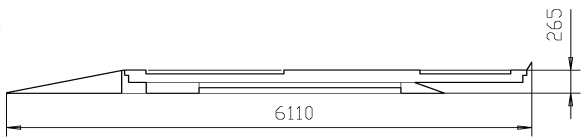
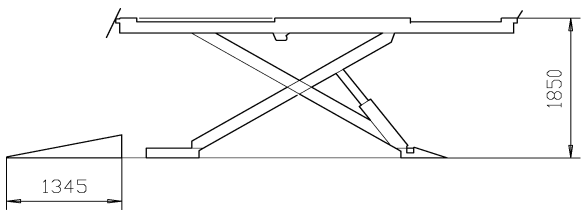

RAV640.2

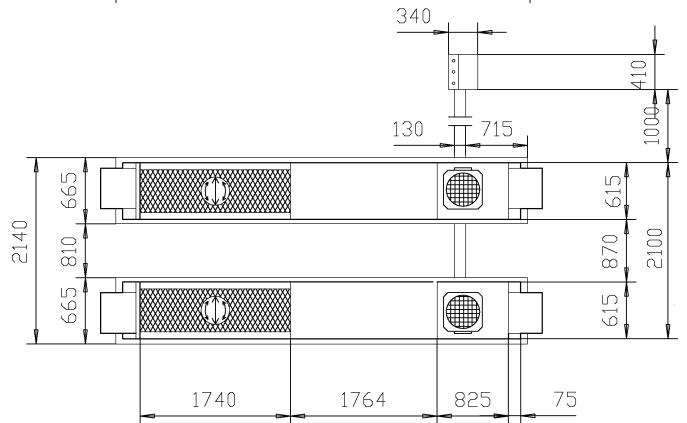
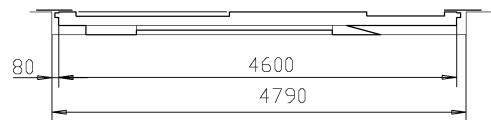
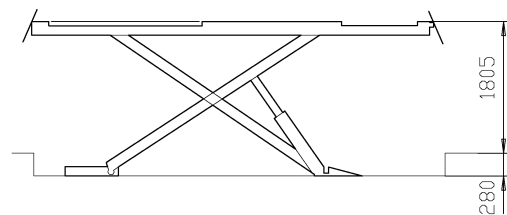

RAV640.2 I

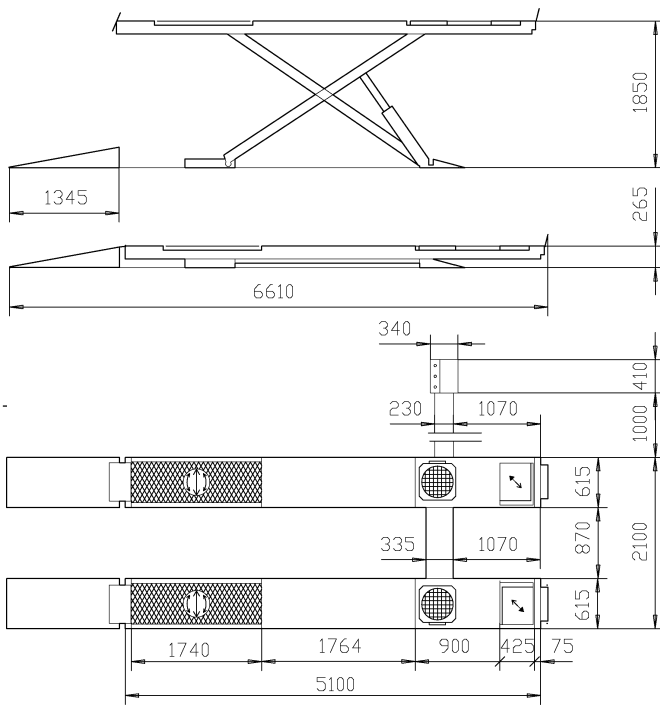

RAV640.3

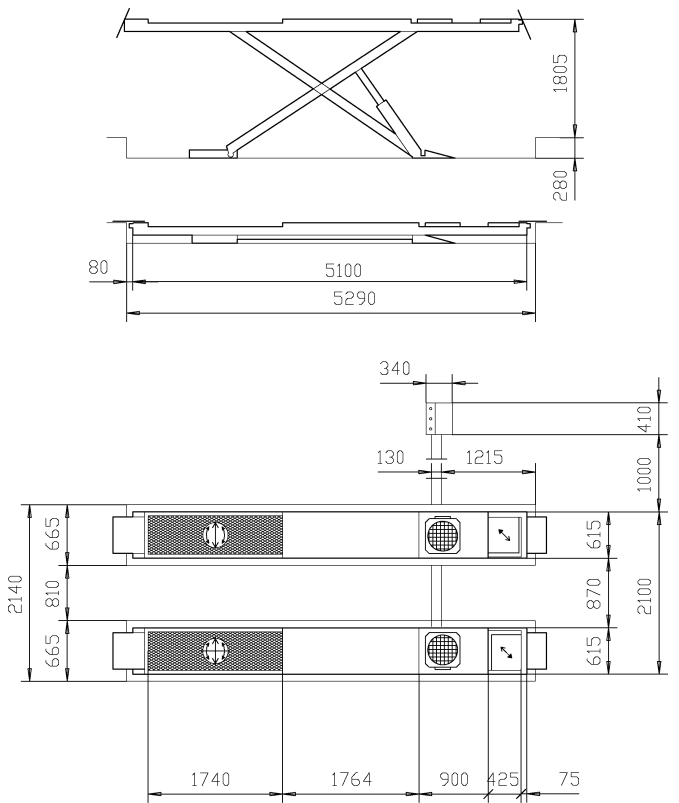

RAV640.3 I

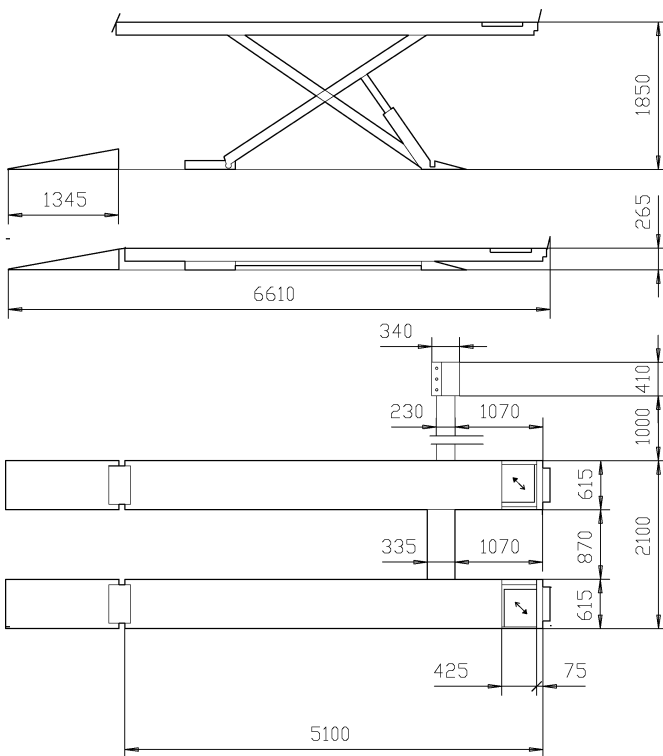

RAV640.4

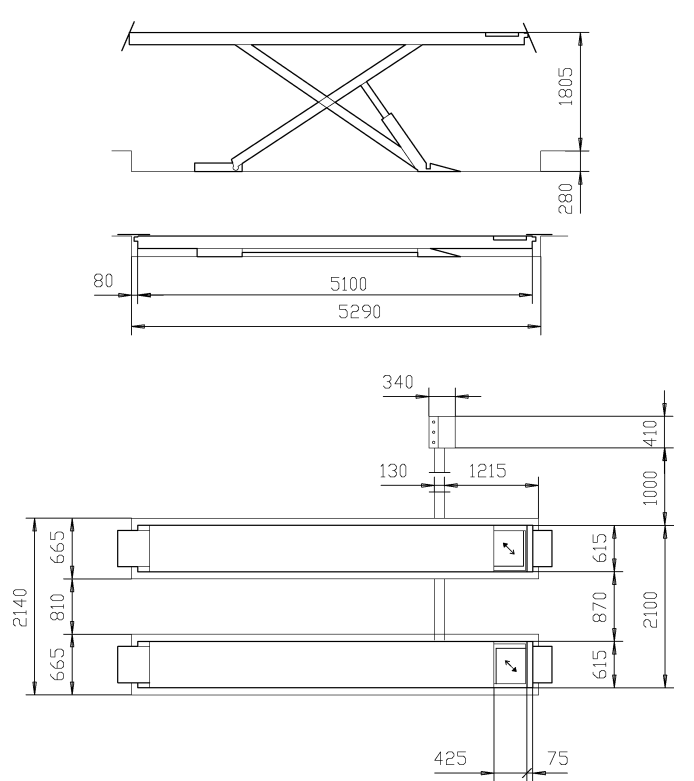

RAV640.4 I

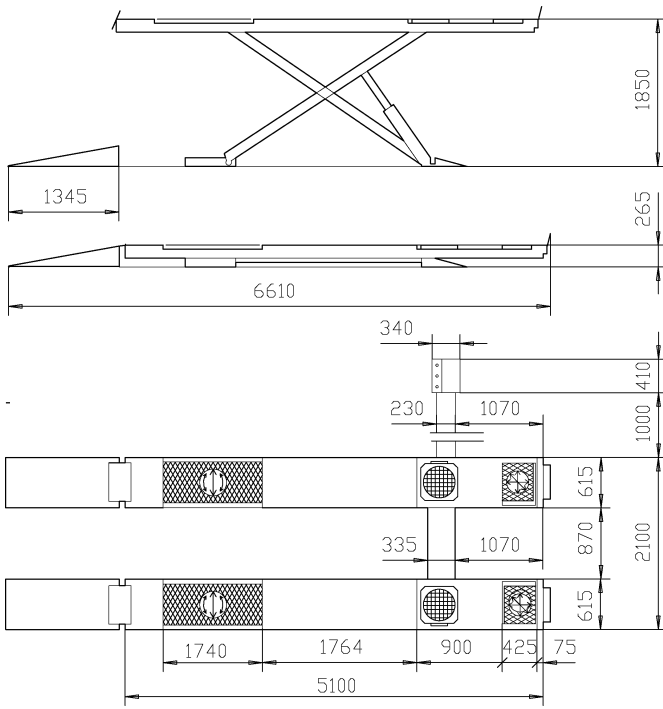

RAV640.5

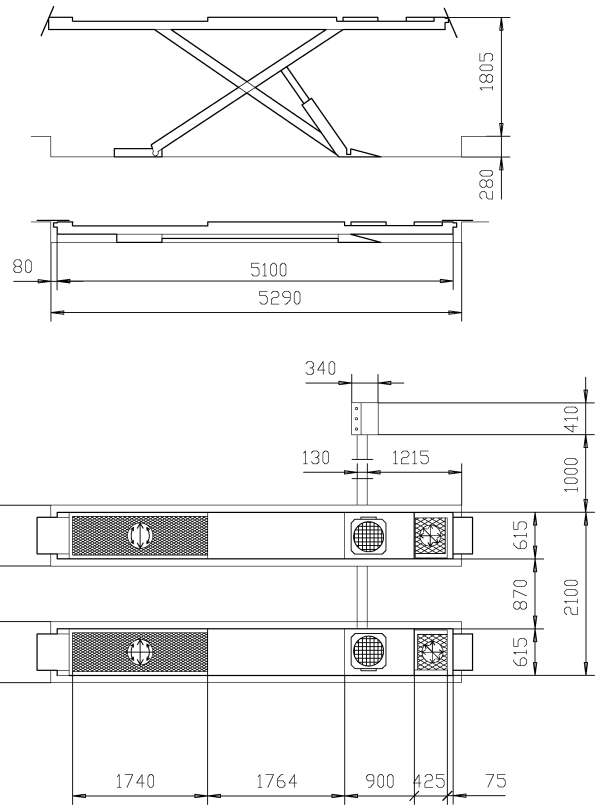

RAV640.5 I

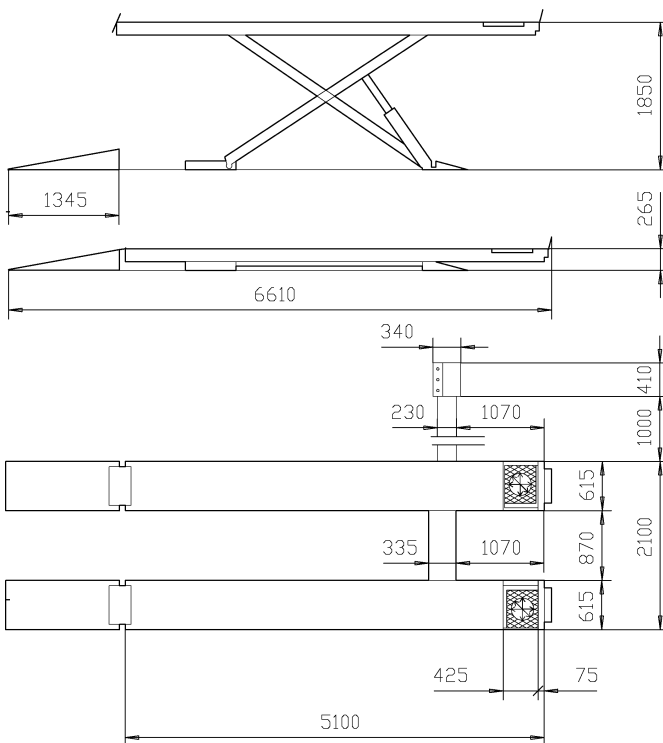

RAV640.6

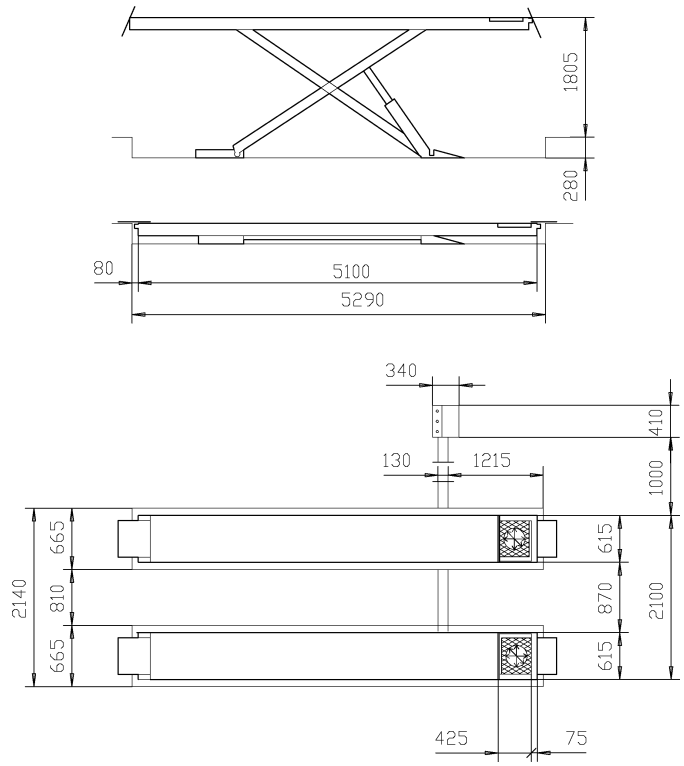

RAV640.6 I

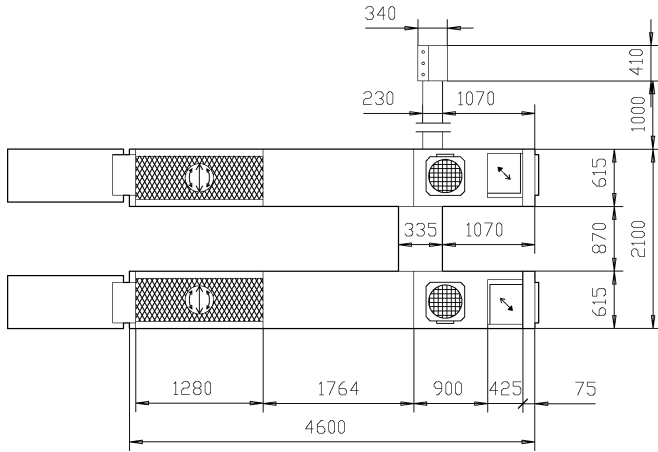
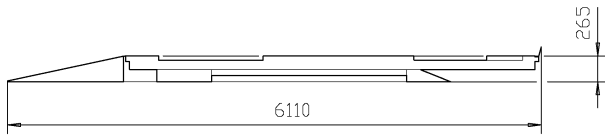
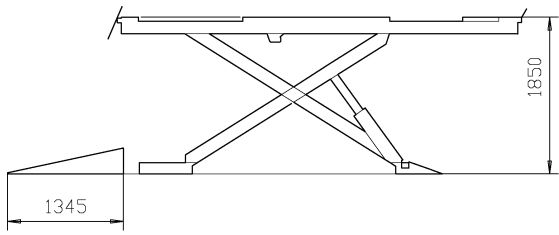

RAV640.3.46

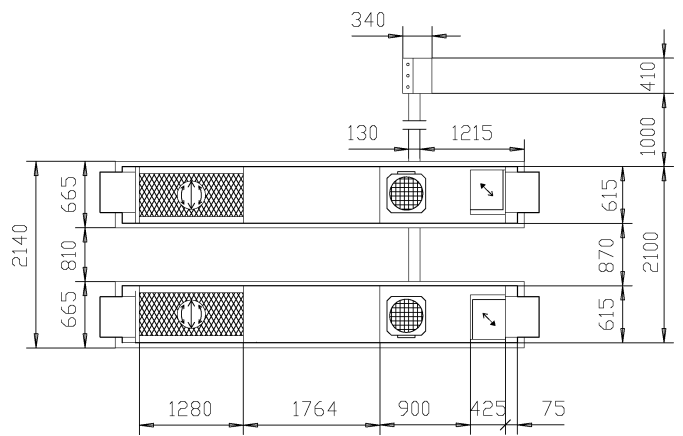
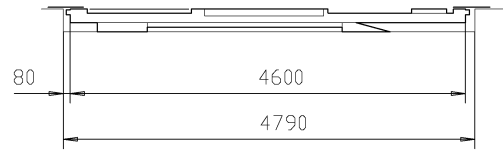
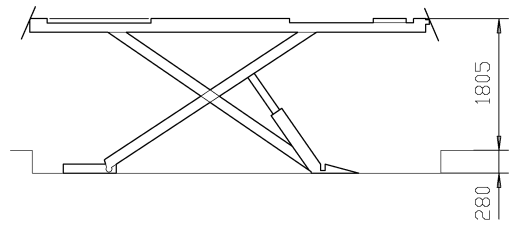

RAV640.3.46 I

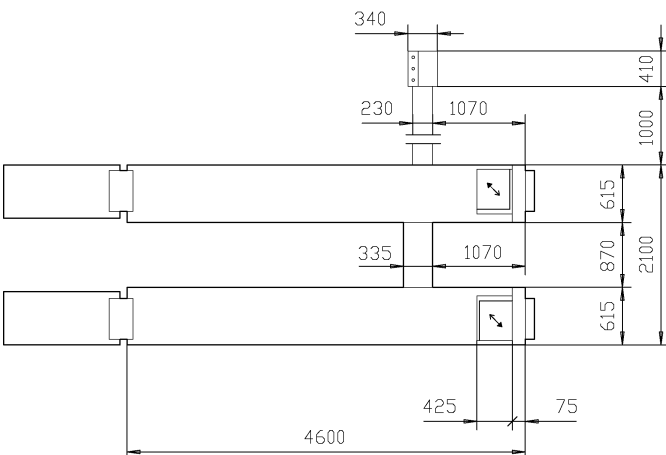
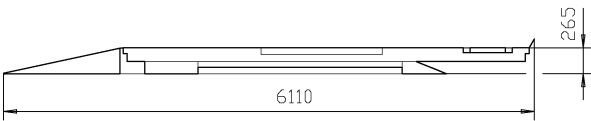
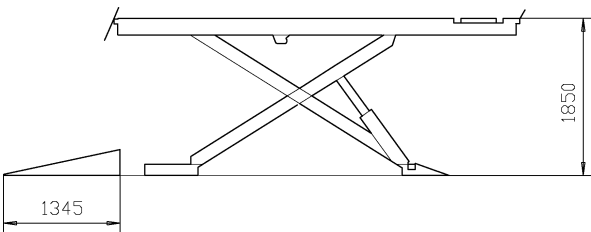

RAV640.4.46

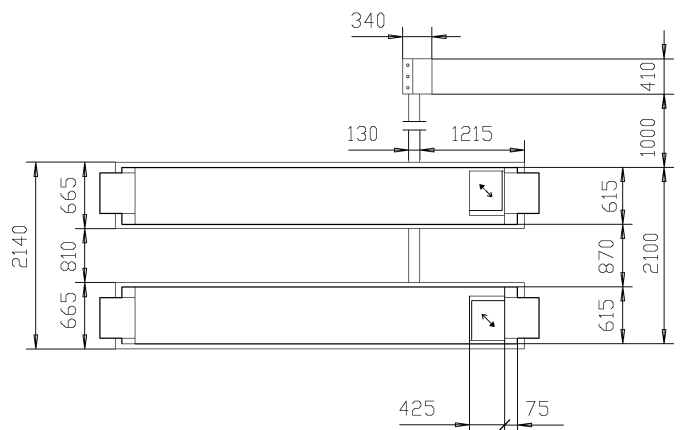
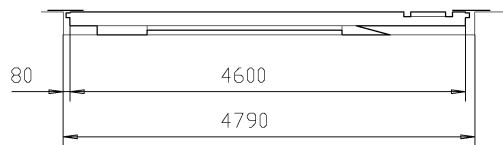
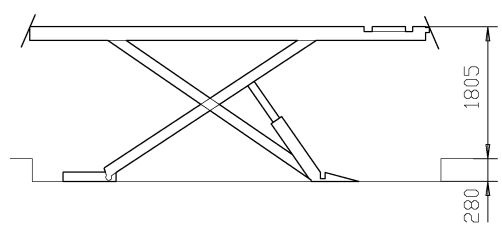

RAV640.4.46 I

**DATI TECNICI - TECHNICAL DATA
RAV640**

CARATTERISTICHE TECNICHE	SPECIFICATIONS	VERSIONE A PAVIMENTO FLOOR LIFT	VERSIONE AD INCASSO RECESSED LIFT
Portata sollevatore (kg)	Lift capacity (kg)	4.200	4.200
Motore (kW)	Motor (kW)	2,6	2,6
Tempo salita sollevatore (") (con carico massimo)	Lift elevation time (") (with maximum charge)	34	40
Tempo discesa sollevatore (") (con carico massimo)	Lift downward movement time (") (with maximum charge)	26	31
Peso (kg) RAV640.1_RAV640.4_RAV640.4.46 RAV640.6	Weight (kg) RAV640.1_RAV640.4_RAV640.4.46 RAV640.6	1.450	1.375
Peso (kg) RAV640.2_RAV640.3_RAV640.3.46 RAV640.5	Weight (kg) RAV640.2_RAV640.3_RAV640.3.46 RAV640.5	1.700	1.625
Rumorosità dB(A)	Noise level dB(A)	≤ 70	≤ 70
Pressione aria (bar)	Air pressure (bar)	Min.6 - Max.10	
Pressione olio max. centralina idraulica (bar)	Hydraulic control box max oil pressure (bar)	270	

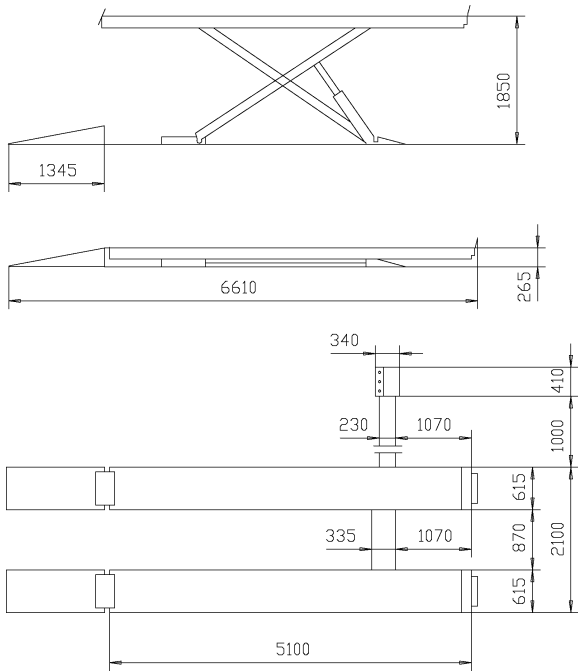

RAV650.1

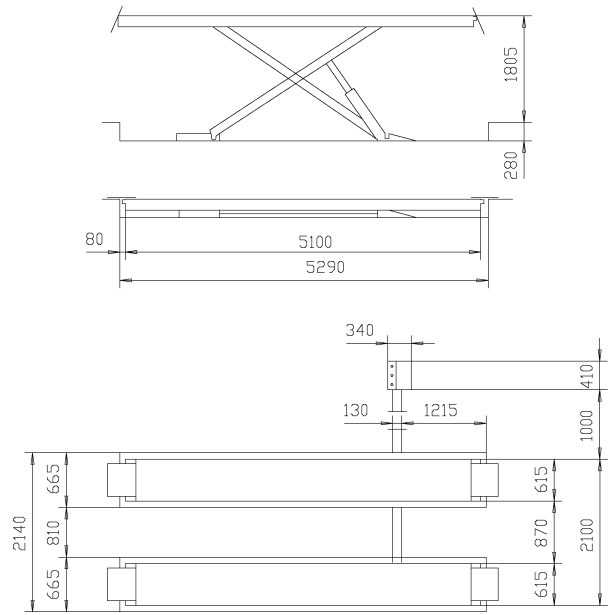

RAV650.1 I

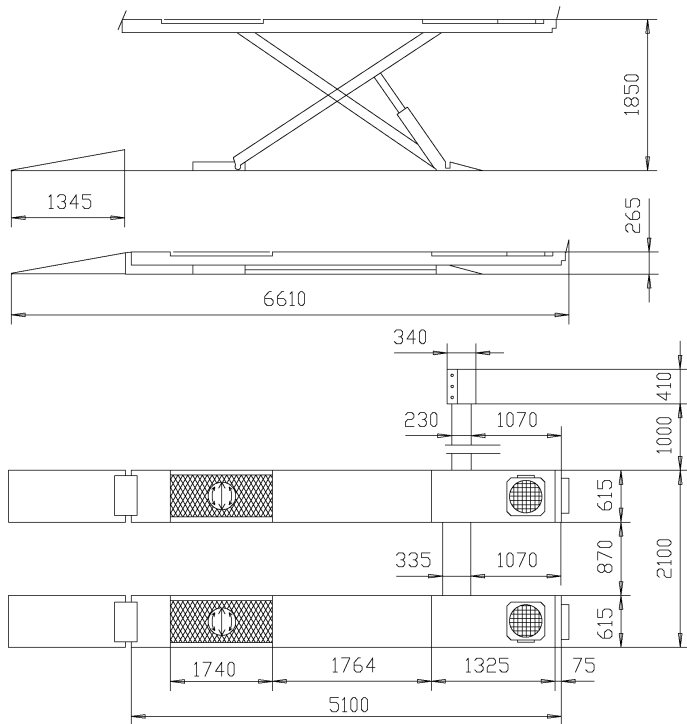

RAV650.2

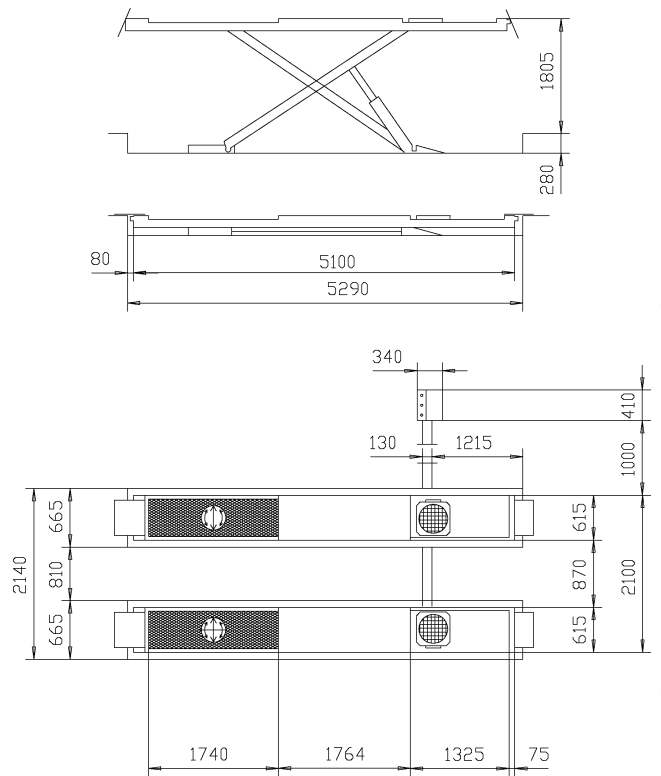

RAV650.2 I

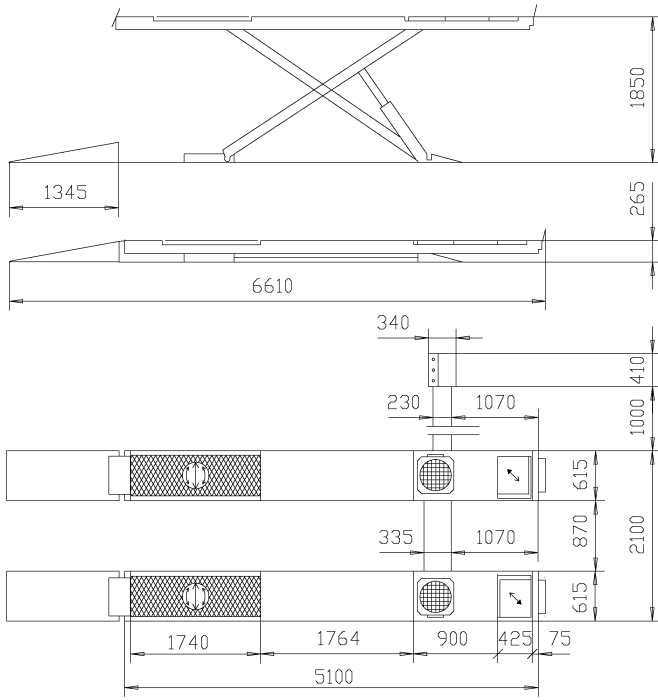

RAV650.3

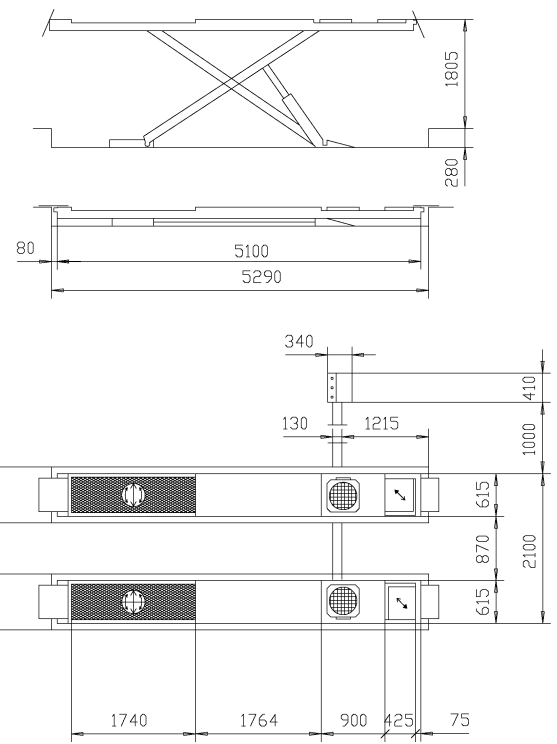

RAV650.3 I

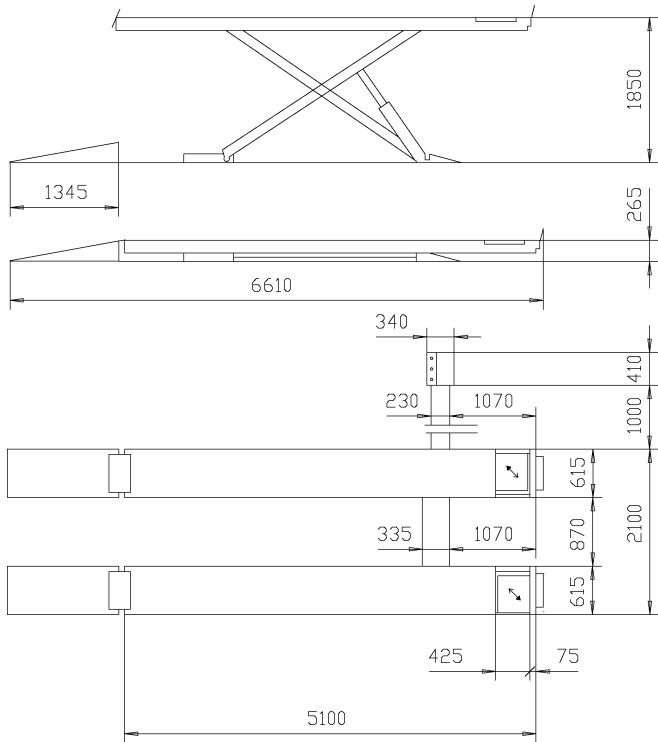

RAV650.4

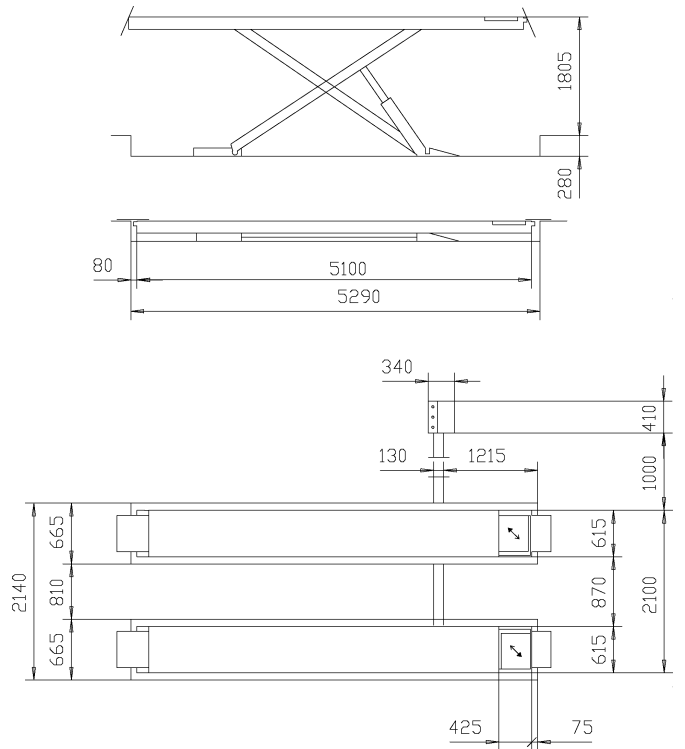

RAV650.4 I

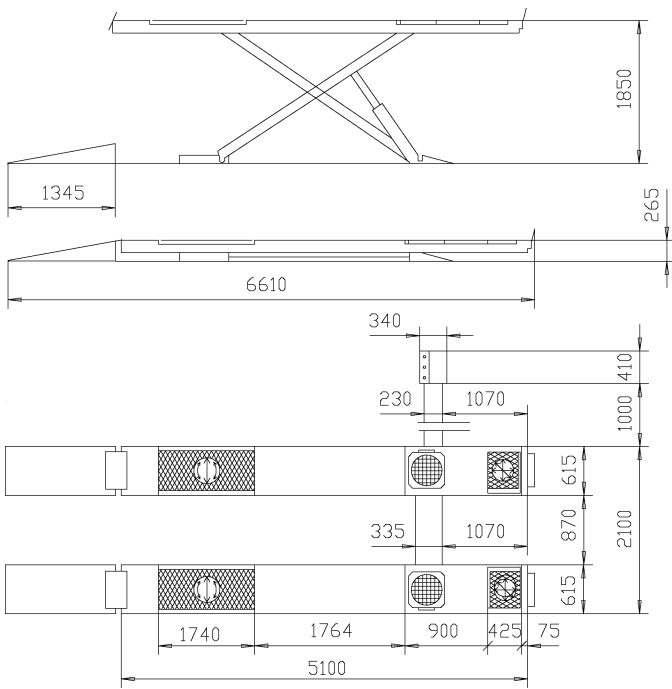

RAV650.5

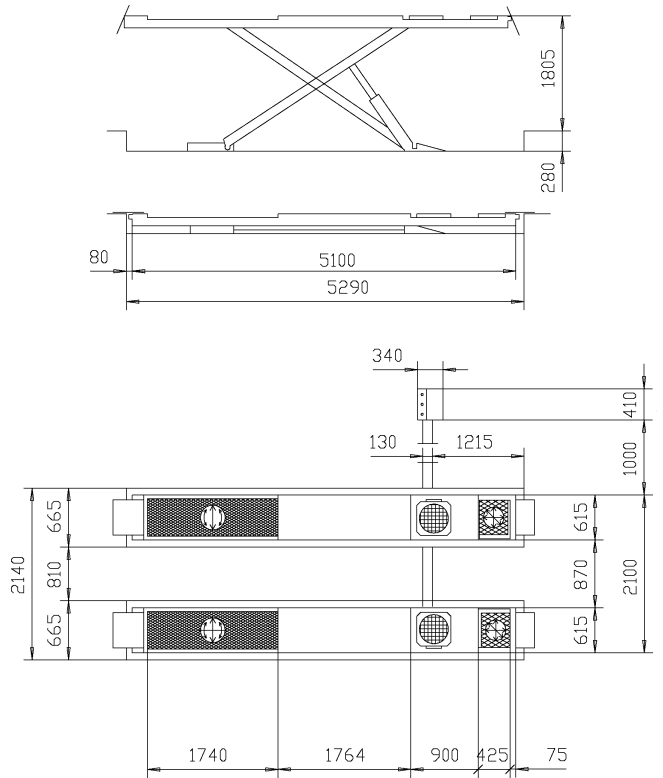

RAV650.5 I

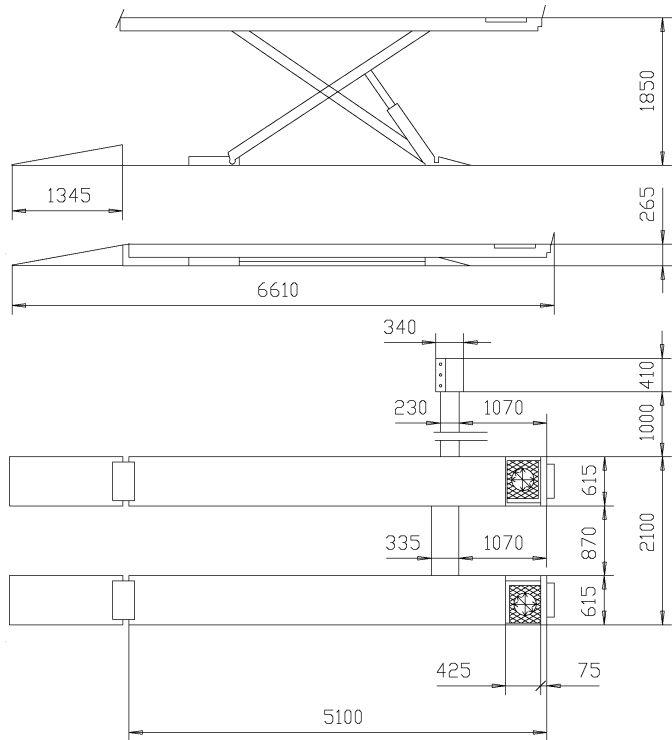

RAV650.6

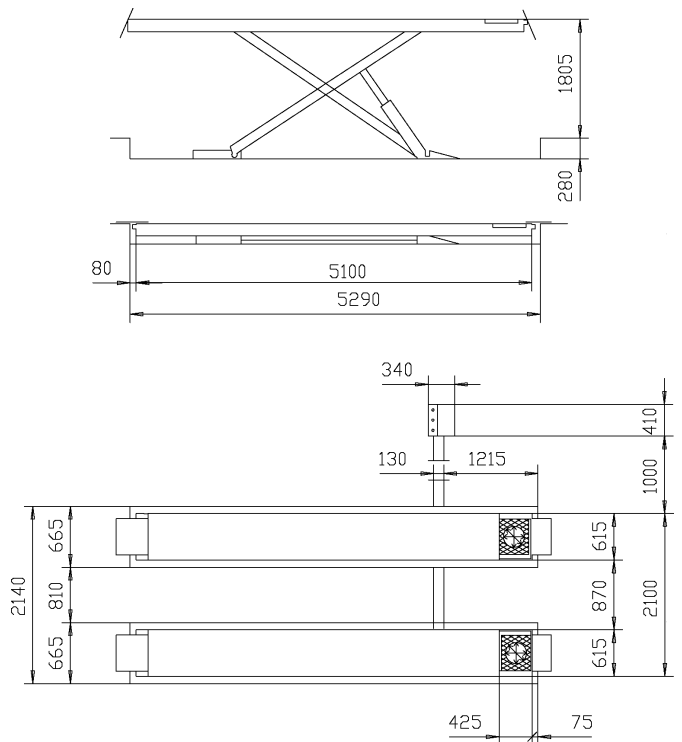

RAV650.6 I

**DATI TECNICI - TECHNICAL DATA
RAV650**

CARATTERISTICHE TECNICHE	SPECIFICATIONS	VERSIONE A PAVIMENTO FLOOR LIFT	VERSIONE AD INCASSO RECESSED LIFT
Portata sollevatore (kg)	Lift capacity (kg)	5.000	5.000
Motore (kW)	Motor (kW)	2,6	2,6
Tempo salita sollevatore (") (con carico massimo)	Lift elevation time (") (with maximum charge)	52	62
Tempo discesa sollevatore (") (con carico massimo)	Lift downward movement time (") (with maximum charge)	32	39
Peso (kg) RAV650.1 - RAV650.4 - RAV650.6	Weight (kg) RAV650.1 - RAV650.4 - RAV650.6	1.450	1.375
Peso (kg) RAV650.2 - RAV650.3 - RAV650.5	Weight (kg) RAV650.2 - RAV650.3 - RAV650.5	1.700	1.625
Rumorosità dB(A)	Noise level dB(A)	≤ 70	≤ 70
Pressione aria (bar)	Air pressure (bar)	Min.6 - Max.10	
Pressione olio max. centralina idraulica (bar)	Hydraulic control box max oil pressure (bar)	270	

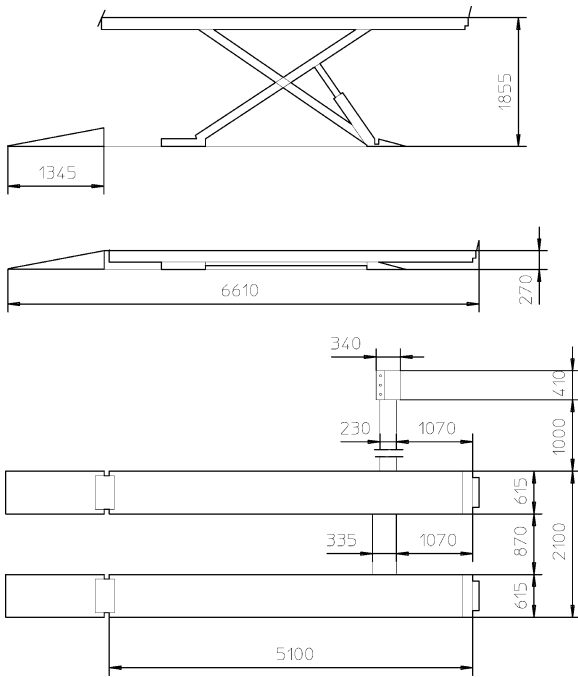

RAV660.1

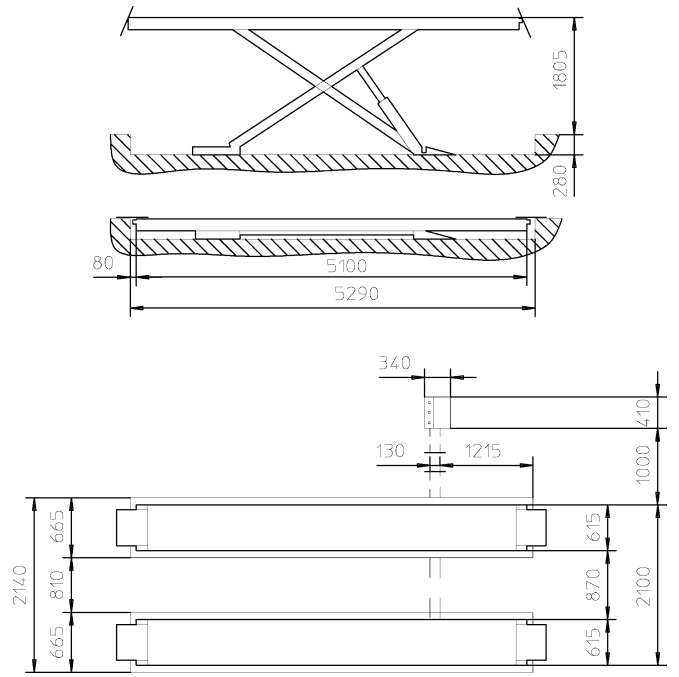

RAV660.1 I

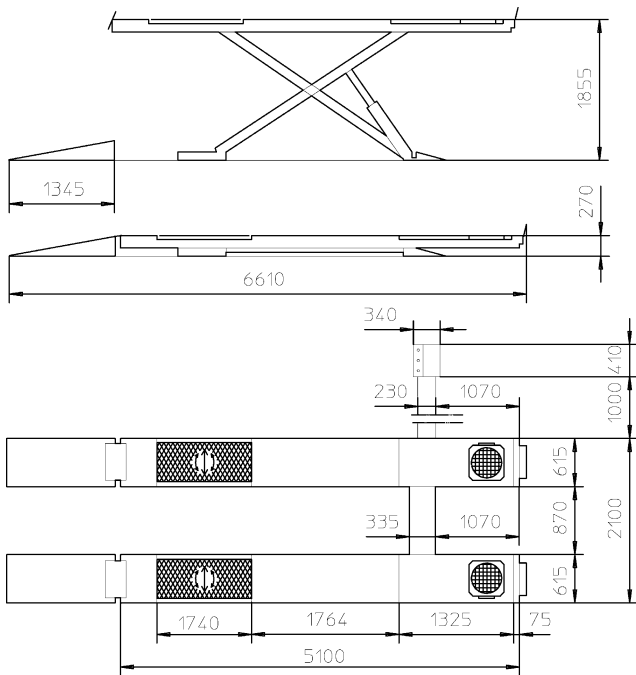

RAV660.2

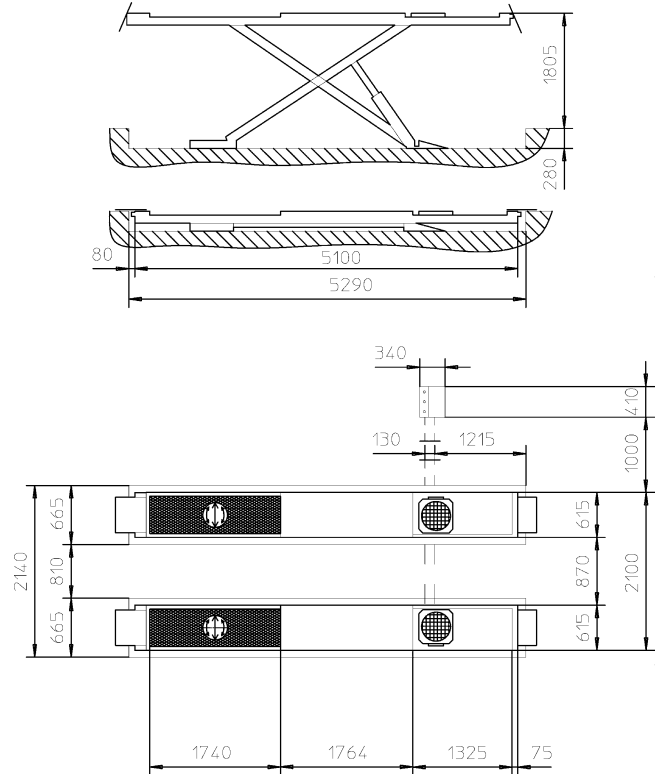

RAV660.2 I

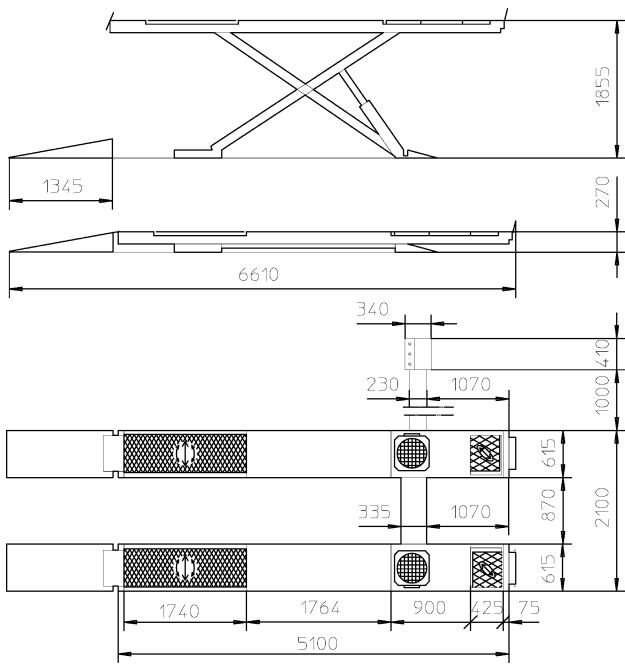

RAV660.3

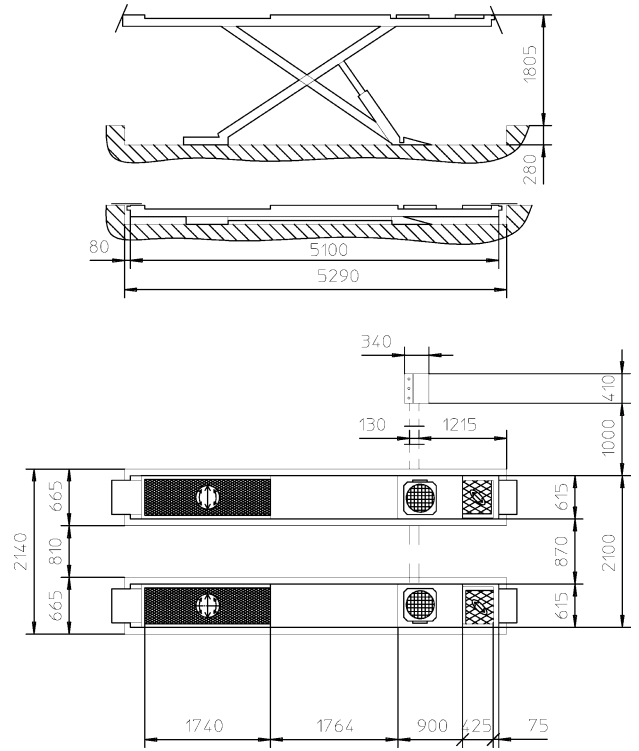

RAV660.3 I

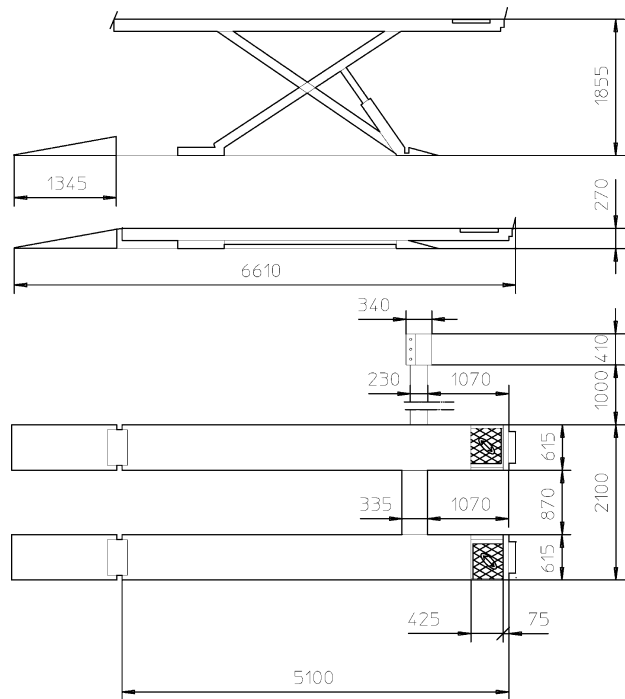

RAV660.4

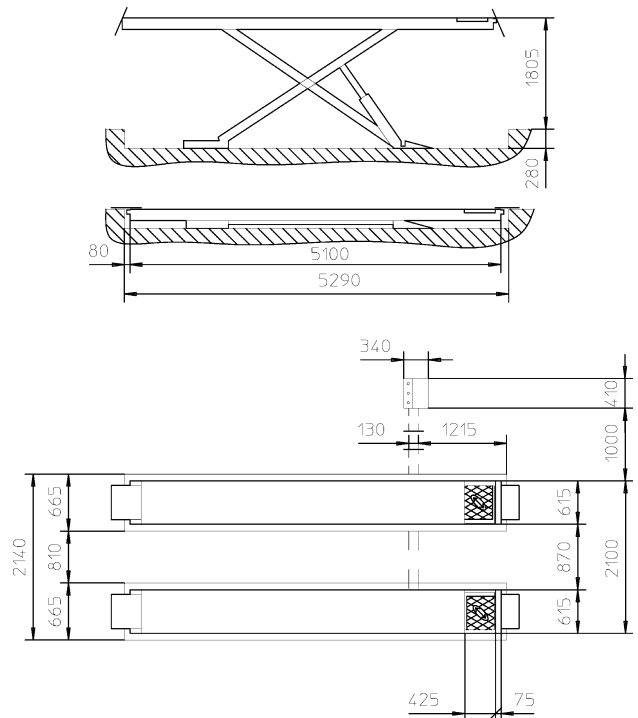

RAV660.4 I

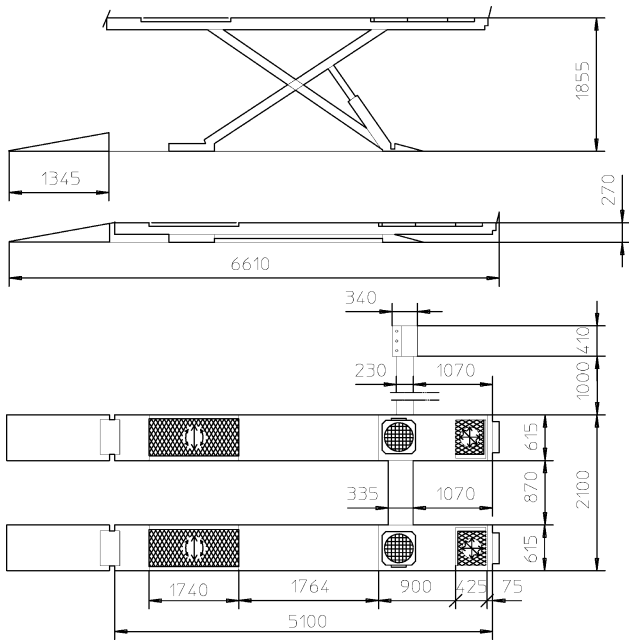

RAV660.5

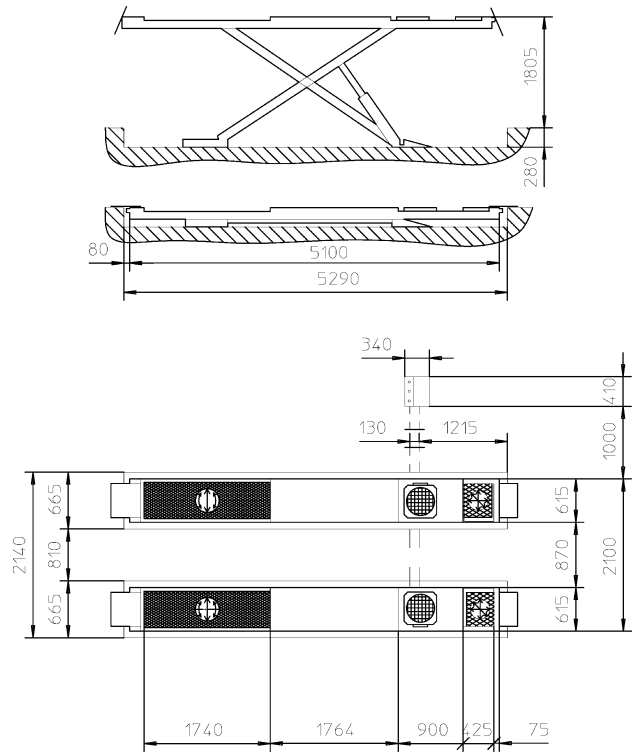

RAV660.5 I

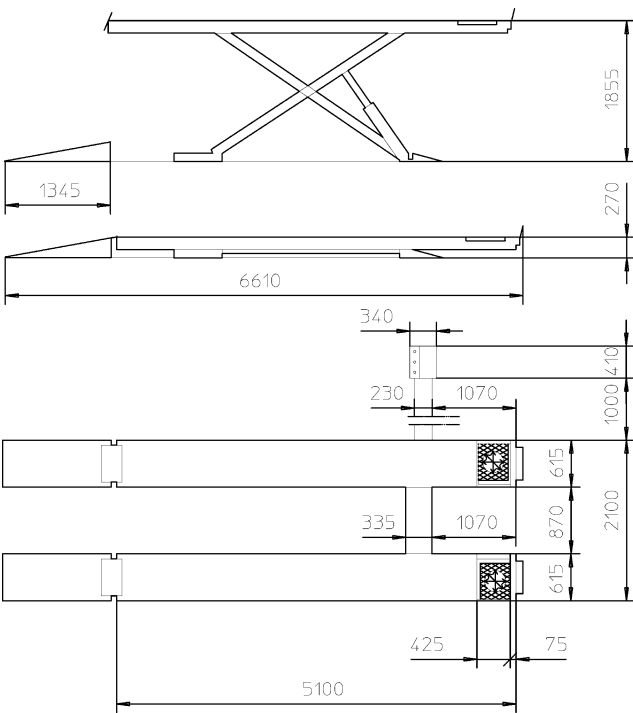

RAV660.6

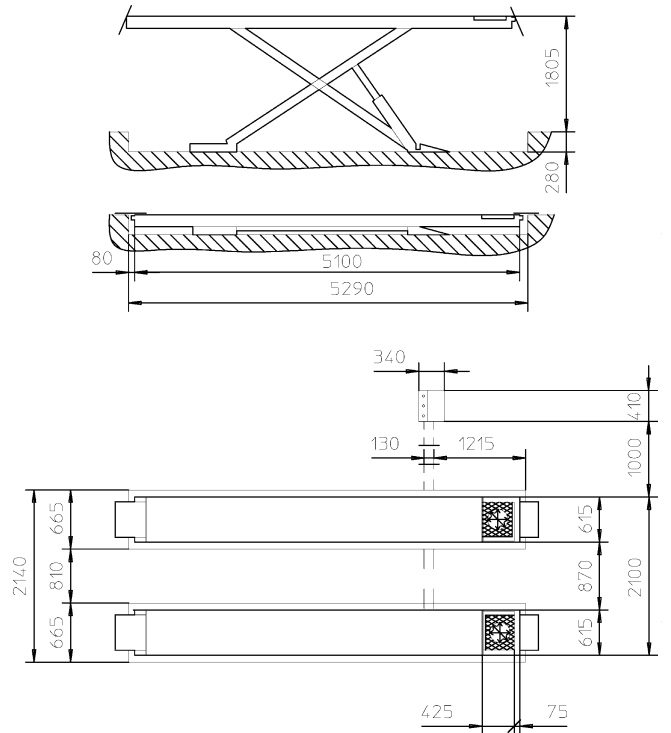

RAV660.6 I

**DATI TECNICI - TECHNICAL DATA
RAV660**

CARATTERISTICHE TECNICHE	SPECIFICATIONS	VERSIONE A PAVIMENTO FLOOR LIFT	VERSIONE AD INCASSO RECESSED LIFT
Portata sollevatore (kg)	Lift capacity (kg)	6.000	6.000
Motore (kW)	Motor (kW)	2,6	2,6
Tempo salita sollevatore (") (con carico massimo)	Lift elevation time (") (with maximum charge)	55	65
Tempo discesa sollevatore (") (con carico massimo)	Lift downward movement time (") (with maximum charge)	32	39
Peso (kg) RAV660.1 - RAV660.4 - RAV660.6	Weight (kg) RAV660.1 - RAV660.4 - RAV660.6	1.465	1.390
Peso (kg) RAV660.2 - RAV660.3 - RAV660.5	Weight (kg) RAV660.2 - RAV660.3 - RAV660.5	1.715	1.640
Rumorosità dB(A)	Noise level dB(A)	≤ 70	≤ 70
Pressione aria (bar)	Air pressure (bar)	Min.6 - Max.10	
Pressione olio max. centralina idraulica (bar)	Hydraulic control box max oil pressure (bar)	270	